



**Stands +  
Lighting Units  
for Image Capturing**

# The View from the Top

When you think about the positions a camera is used in relation to the subject to be photographed, two possibilities come into mind:

First there is the well-known posture with the camera - sometimes mounted to a tripod - in front of our eye aiming at the subject, either from the front, the side, from below or at an angle from above. The three dimensions of the subject are always preserved, the type of picture only depends from the chosen perspective.

Then there is the vertical view from above where usually the third dimension is lost.

But that is not important for this perspective. In fact this arrangement is for capturing subjects photographically, that are two-dimensional anyway or where surface, structure, pattern or array etc. is the point. This extends to the aerial photograph, that - taken from an absolute vertical position - will serve as a basis for the production of maps.

Back to earth, this camera position is often used for „reproductions“. In general a reproduction is understood as a faithful rendition of a copy in a different scale. Even if the reproduction does not stay that „faithful“, the copy has to be captured first in its original form. Devices for reproduction or „copying“ are well known to all of us. Photocopiers and flatbed scanners are such devices. Actually everybody who owns a camera has such a „copying machine“ provided that the lens will make a sharp picture at the necessary distance.

„If you want to do reproductions with an ordinary camera, the use of a -> stand or a copying device is indispensable.“ (Urs Tillmanns, Photo Encyclopedia, Schaffhausen 1991).

And here we are, dealing with the subject.



As „faithful rendition“ is not always necessary any more, we should perhaps not speak of reproductions, but of a special way of „image capturing“, because this has no meaning with respect to the rendition of the „captured“ subject. And this fits today's digital photographic world much better. Much of the „capturing work“ is done by the flatbed scanner, often limited to letter format sizes, but cameras will also find many fields of application here.

The indispensable stand for that purpose, the often equally essential lighting equipment and many more useful helpers can be found on the following pages. Only when copy stage and storage stage – i.e. the plane of the sensor – are absolutely parallel, all angles are exactly the same as the original is and the captured image is in accordance with the original's geometry.

Therefore camera stands for image capturing applications must be stable and precise. They usually have a baseboard to carry the original (sometimes with an integrated lighting system for transparent originals), a column and a camera arm. Various lighting units are available for reflective originals.

The height of the camera arm can be continuously adjusted on the column. In this way the desired frame and reproduction ratio can be set with high precision and consistent parallelism.

Depending on the size and weight of the camera, the size and nature of the original and other requirements there are camera stands in different sizes and lighting units in various configurations. Please read the next pages to get acquainted with the respective product families.



# Family Relationships

Combined with a suitable camera, stand and lighting equipment represent a complete problem solution for image capturing tasks. Kaiser has organized these camera stands and lighting units in different system families. We use the term „system“ because all devices can be adapted to various requirements due to their modular construction and additional upgrade components.

Grouping the devices in families, links units and components that fit together and function together. Besides that, it helps to find the best choices for the specific requirements of the job.

Especially when choosing the light it is essential, that it is suitable and adequate. It is suitable when dimensions and stability match with the type of camera stand. That is why you will find the suitable lighting units always within the same system family.



## The rePRO system

For professional requirements in conventional and digital image capturing.



## The RD system

The professional system for the digital world.



## The Copylizer system

A universal image capturing tool with integrated trans-illuminator.

Many factors have to be considered when checking if the lighting equipment is adequate: size, nature and reflection properties of the photographic subject as well as the type of „film“ used in the camera. Especially with conventional chemical film the color temperature of the light should „fit“ the film.

When using digital „film“, that is in digital photography, new requirements can be important depending on the way, sensor elements are arranged (chip or line). Especially with line scanning cameras and cameras or backs using microscanning or multishot mode, there is a demand for high stability of the light. High-frequency lighting systems are the preferred solution.



### The R1 system

High flexibility and extraordinary adaptability are the key features and enable even the accomplishment of very special jobs.



### The R2 system

A „amateur system“, also suitable for certain professional requirements.



### The reprodik

Everything becomes smaller, lighter, more compact.

# A Survey to Begin with

In the tables on these pages you will find all essential specifications of stands and lighting units for image capturing. They provide a quick survey and an easy comparison of selected data.

Most notably they comprise some important information for practical application: the maximum covered original width in relation to specific focal lengths of lenses as well as values of illuminance and feasible exposure time settings with the lighting units.

## STANDS

Designation	Code no.	Column height (cm/in.)	Baseboard or illumin. area (i.a.) (cm/in.)	Original width <sup>1</sup> (cm/in.) for focal length of lens <sup>2</sup> 50 mm    100 mm		Suitable lighting unit	
<b>RSP rePRO</b>	5612 with 5615 and 5616/5617	150/59.1 66/26.0	80x60/31.5x23.6, i.a. 48x43/18.9x17	88/34.6	44/17.3	5656/5657	rePRO
<b>RSP 2motion</b>	5710	216/85.0	100x80/39.4x31.5	100/39.4	50/19.7	3425/3428/3431 (see page 42)	
<b>RSP Xtra</b>	5711 with 5712 with 5630	216/85.0 49/19.3 32/12.6	- 86x60/33.9x23.6 86x60/33.9x23.6	- 100/39.4 112/44.1	- 50/19.7 56/22.1		
<b>RSD / RSD mot</b>	5602/5603	120/47.2	68x57/26.8x22.4	60/23.6	30/11.8	5565/5589/5590/5588/ 5558/5557/5556/5591/ 5595/5552/5554/5563 <sup>3</sup>	RD
<b>Copylizer exe.cutive</b>	5232 5212	100/39.4 100/39.4	i.a. 43x35/17x13.8 i.a. 43x35/17x13.8	53/20.9 53/20.9	27/10.6 27/10.6	5276/5277/5280/5281 5276/5277/5280/5281	Copylizer
<b>Copylizer ini.tial</b>	5211 5205/5206	100/39.4 67/26.4	i.a. 43x35/17x13.8 i.a. 20x18/7.9x7.1	53/20.9 35/13.8	27/10.6 17/6.7	5270 5267	
<b>RSX</b>	5512	120/47.2	60x50/23.6x19.7	66/26.0	33/13.0	5589/5590/5588/ 5558/5557/5556/ 5591/5595/5552/ 5554/5563 <sup>3</sup> /5565	R1
<b>RS 10</b>	5513	100/39.4	60x50/23.6x19.7	53/20.9	27/10.6		
<b>RS 1</b>	5510	100/39.4	45x50/17.7x19.7	53/20.9	27/10.6		
<b>RS 1</b>	5511	100/39.4	45x50/17.7x19.7	53/20.9	27/10.6		
<b>RS 1 microdrive</b>	5507	100/39.4	45x50/17.7x19.7	53/20.9	27/10.6		
<b>RS 2 XA</b>	5411	76/29.9	40x50/15.7x19.7	38/15.0	19/7.5	5464/5465/5450	R2
<b>RS 2 CP</b>	5301	60/23.6	40x42/15.7x16.5	29/11.4	15/5.9	5464/5465	
<b>reprokid</b>	5360/5361	59/23.2	32x38/12.6x15.0	33/13.0	16/6.3	included with 5360	
<b>Vertikal Stand</b>	4405/5503 4406/5503	63/24.8 100/39.4	32x42/12.6x16.5 32x42/12.6x16.5	34/13.4 53/20.9	17/6.7 27/10.6		

<sup>1</sup> at maximum height    <sup>2</sup> focal length is related to full frame    <sup>3</sup> in connection with 5560 holding rods

## LIGHTING UNITS

Designation	Code no.	Power <sup>7)</sup> (Watt)	Color temp. (Kelvin)	Illuminance (Lux) <sup>4)</sup>	Time/ Aperture <sup>5)</sup>	Suitable camera stand	Replacement lamp code	
<b>RB 5056 HF</b>	5656/5657	4 x 55	5400	7900	1/30	5612 with 5615 and 5616/5617	3454	rePRO
<b>RB 5070 DX</b>	5565	2 x 22	5600	4000	1/15	5602, 5603, 5512, 5513, 5510, 5511, 5507	(LED)	RD
<b>RB 4.55 HF</b> <b>RB 4.36 HF</b> <b>RB 2.36</b> <b>RB 2.18N HF</b>	5280, 5281 5276, 5277 5270 5267	4 x 55 4 x 36 2 x 36 2 x 18	5400 5400 5400 5400	7500 4700 1500 1160	1/30 1/15 1/8 1/4	5232, 5212 5232, 5212 5211 5205, 5206	3454 5567 5567 5458	Copyizer
<b>RB 5055 HF</b> <b>RB 5004 HF</b> <b>RB 5004</b> <b>RB 5000 DL</b> <b>RB 5003 UV</b> <b>RB 300</b> <b>RB 104</b>	5589/5590 5558/5588 5557 5556 5591/5595 5552 5554	4 x 55 4 x 36 4 x 36 2 x 36 6 x 18 2 x 300 4 x 25 4 x 75 4 x 150 4 x 150 4 x 250 2 x 150	5400 5400 5400 5400 UV-A, wave length 366 nm 3200 6400 3000 4200 3200 3000 3200	7900 4900 3100 1600 9000 2200 2200 4200 10000 20000 5000	1/30 1/15 1/15 1/8 1/30 1/8 1/8 1/15 1/30 1/60 1/15	5512, 5513, 5510, 5511, 5507	3454 5567 5567 5567 5569 3038 3110 <sup>6)</sup> 4356 <sup>6)</sup> 3124 <sup>6)</sup> 3128 <sup>6)</sup> 3130 <sup>6)</sup> 3128 <sup>6)</sup>	R1
<b>RB 3<sup>3)</sup></b>	5563	2 x 300 4 x 25 4 x 75 4 x 150 4 x 150 4 x 250 2 x 150	3200 6400 3000 4200 3200 3000 3200	9000 2200 2200 4200 10000 20000 5000	1/30 1/8 1/8 1/15 1/30 1/60 1/15			
<b>RB 218N HF</b> <b>RB 5020 DS</b> <b>RB 2</b>	5464 5465 5450	2 x 18 2 x 14,5 4 x 75	5400 5600 3000	1160 6000 3000	1/4 1/15 1/15	5301, 5411 5301, 5411 5411	5458 (LED) 4356 <sup>6)</sup>	R2
<b>R2N CP</b>	5304	4 x 150 2 x 18	3000 5400	6000 1160	1/15 1/4	5411 included (5464)	3124 <sup>6)</sup> 5458	
<b>reprokid</b>	5360	2 x 150	3200	14000	1/60	included	3128 <sup>6)</sup>	

<sup>3)</sup> in connection with 5560 holding rods

<sup>4)</sup> measured with highest possible evenness of illumination in consideration of the adjustability on the lamp arms to the subject surface: tabloid format, R2 system and reprokid: letter format

<sup>5)</sup> approx. exposure time in seconds at f=8

<sup>6)</sup> not included. 3128 is a reflector lamp, 3124, 3130, 4356 are lamps without reflector, 3110 is an energy saving lamp

<sup>7)</sup> power consumption of lamps

# Professional in Every Respect



When you need a maximum in stability, solidity and load capacity, the Kaiser rePRO system is the right choice.

This system is not only at home in photo and video studios, but also in technology, forensics and science, education, research and media production. Because of its extremely high level of stability the rePRO

system is especially suitable to capture large format reflective or transparent originals.

This modular-designed stand is available in several versions: with a table

with fixed working height, with a motorized height-adjustable table and without a table.

According to the job, the table with fixed working height can be equipped with a large base plate or with a transilluminator for translucent originals.

Height adjustment of camera level is motorized and works individually along the entire column via remote control. The camera platform can travel up and down at two speeds, regardless of the supported load.

The version with height-adjustable table has a motorized table and a motorized camera carrier that can be moved along the complete height of the column. This offers enormous flexibility with respect to shooting distance and possible working positions. The version without a table provides for a different sort of flexibility, because it can be combined with various existing working planes.

For precise positioning of the optical axis of the camera, the camera carrier can be shifted horizontally and, in addition, can be tilted by +/- 90 degrees.

The column, made of a multi-section special extrusion, is mounted to a firmly attached die-cast base and is extremely sturdy and vibration-resistant.

These professional work stations - equipped with a suitable camera system of your choice - offer optimum conditions for sophisticated image capturing tasks.



## 5612 Column

Made of special aluminum tube, black anodized, with printed cm and inch scales. Height adjustment motorized, with two speeds. Cable remote control. Constant adjustment speed, independent of load. Any height position is exactly held via self-limiting worm-gear. Automatic end switch by photo sensors. Camera platform horizontally adjustable by parallel guides with friction drive, hand cranks for right-hand/left-hand operation, two locking screws. Build-in spirit level. Camera mounting plate 13 x 13 cm (5.1 x 5.1 in.), tiltable by +/- 90°.

Column height: 150 cm (60 in.)  
Maximum load: approx. 15 kg (33 lbs.)  
Mounting thread: 1/4" / 3/8" exchangeable

## 5615 Table Frame

With aluminum die-cast base for 5612 column. Demountable steel tube construction. Stacking tray 80 x 50 cm (31 x 20 in.) Height-adjustable feet.

Height without base: approx. 88 x 66 x 78 cm (34.6 x 26 x 30.7 in.), required floor space: 88 x 104 cm (34.6 x 41 in.).

## 5617 Trans-Illuminator

To be inserted in the 5615 table frame. Illuminated area 48 x 43 cm (18.9 x 16.9 in.), glass cover plate. Total working area 80 x 60 cm (31.5 x 23.6 in.)

Lamps: 4 x 55 W. Continuously dimmable. Built-in fan cooling, no thermal load on originals. Luminance 6700 cd/m<sup>2</sup>, high-frequency operation. Color temperature of lamps 5400 K, CRI = 90-100. Average service life approx. 8000 hours.

## 5627 Close-up Adapter

Bracket to reduce the minimum camera-to-baseboard distance. Mounts on the camera carrier.

## 4421 rePRO Adapter

For use of R1 system camera arms.



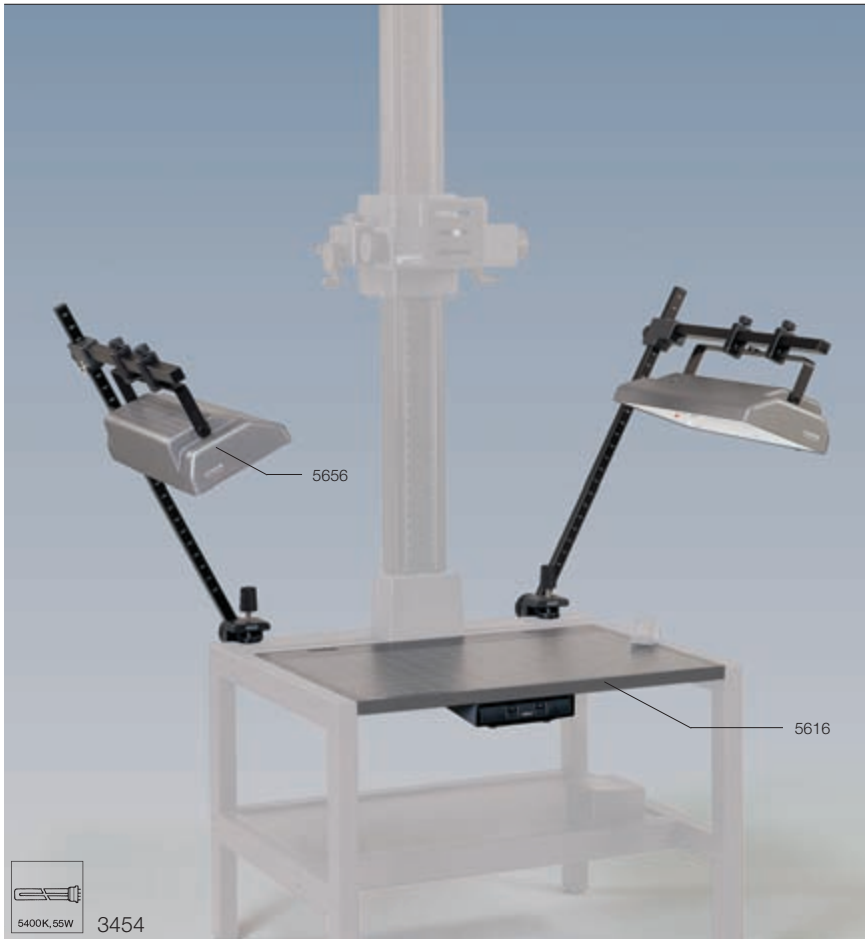

## 5656-57 RB 5056 HF Lighting Unit

**5656:** Two light banks with high-gloss inside reflectors. Light emitting area 64 x 21 cm (25.2 x 8.3 in.) each. Each bank is equipped with two 55 watt daylight fluorescent lamps, color temperature 5400 K, CRI = 90-100. All-electronic high-frequency operating system (approx. 40 kHz) for immediate ignition and flicker-free operation, can be used with line scanner, micro scanning and multi-hot digital cameras and backs. Lights can be tilted and shifted. Horizontal lamp arms can be adjusted continuously in height. Vertical lamp arms with height markings, tiltable with detents. Mounted with strong die-cast clamp bases, clamp width 15 to 55 mm (0.6 - 2.1 in.). Separate control box. Lamps can be switched individually. Cord: 2.50 m (8 ft.)

**5657:** extra: continuously dimmable

## 5592 Filter Holder

Guide rails for slide-in filters for attachment to 5656/5657. Two pairs.

## 5593 Diffusion Screens

Fine-structured acrylic glass. Slides in 5592 filter holders. 2 pieces.

## 5594 Polarizers

Attaches to 5656/5657 with help of 5592 filter holders. 2 pieces.

## 5616 Base Board

To be inserted in the 5615 Table Frame. Dimensions (WXD): 80 x 60 cm (31.5 x 23.6 in.). High-compressed wooden material, all-side plastic-laminated, with printed grid and cm and inch scales. Includes slide-in carrier for control box of optional lighting unit.

## 5614 Wall Mount

For wall mounting the 5612 column and the columns of 5710/5711. Lower part with base, spirit level and compartment for power supply. Top section adjustable for vertical column positioning. Screws and dowels included.

Distance wall - column: approx. 35 cm (13.8 in.)

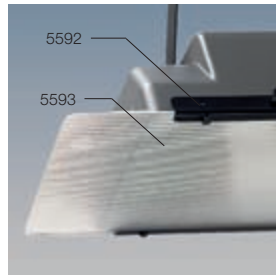

## 5710 „RSP 2motion“ Camera Stand

Heavy-duty copy stand for analogue and digital image capturing work with two-level motor-driven adjustment. Accepts originals up to 100 x 80 cm (39.4 x 31.5 in.).

Extremely sturdy column, made of a multi-section special extrusion, black anodized, with printed cm and inch scales.

Column foot made of double strutted steel tube. Steel socket for bolting the column. Four levelling feet.

Base board made of 4 mm aluminium with stabilizing substructure.

Camera carrier made of die-cast aluminium, horizontally adjustable by parallel guides with friction drive and hand cranks for right-hand/left-hand operation. Two blocking screws. Camera mounting plate tiltable by +/- 90°. Built-in spirit level.

Camera carrier and base board with individual motorized height adjustment. Two travel speeds, independent of load. Self-limiting worm gear: any height position is exactly held. Automatic end switch by photo sensors. Anti-collision device. Cable remote control.

### Specifications:

Total height: 227 cm (89.4 in.)  
Maximum working span: 160 cm (63 in.)  
Column cross section: 120 x 80 mm  
(4.7 x 3.1 in.)

### Maximum load

on camera carrier: 10 kg (22 lbs.)  
on base board: 15 kg (33 lbs.)

Base board: 100 x 80 cm  
(39.4 x 31.5 in.)

Camera platform: 13 x 13 cm  
(5.1 x 5.1 in.)

Connecting thread: 1/4" / 3/8"  
(interchangeable)

Required floor space: 100 x 126 cm  
(WxD) (39.4 x 49.6 in.)

## 5713 Sheet Steel Plate

Fits on top of the RSP 2motion stand base board. For holding originals with magnetic holders (not included).

Dimensions: 1000 x 0.75 x 800 mm  
(39.4 x 0.03 x 31.5 in.)





## 5711 „RSP Xtra“ Camera Stand

Heavy-duty copy stand for analogue and digital image capturing work with motor-driven height adjustment. Extremely sturdy column, made of a multi-section special extrusion, black anodized, with printed cm and inch scales. Column foot made of double strutted steel tube. Steel socket for bolting the column. Four levelling feet.

Camera carrier made of die-cast aluminium, horizontally adjustable by parallel guides with friction drive and hand cranks for right-hand/left-hand operation. Two blocking screws. Camera mounting plate tiltable by +/- 90°. Built-in spirit level. Camera carrier with motorized height adjustment. Two travel speeds, independent of load. Self-limiting worm gear: any height position is exactly held. Automatic end switch by photo sensors. Cable remote control.

Stand is supplied without base board, intended to be used with table 5712, 5630 (see page 106) or custom-made devices.

Total height: 227 cm (89.4 in.)  
 Column cross section: 120 x 80 mm (4.7 x 3.1 in.)  
 Maximum load: 15 kg (33 lbs.)  
 Camera platform: 13 x 13 cm (5.1 x 5.1 in.)  
 Connecting thread: 1/4" / 3/8" (interchangeable)  
 Required floor space (WxD): 83 x 114 cm  
 (32.7 x 44.9 in.)

## 5712 Table for Copying Works

Wheeled table for "RSP Xtra" Camera Stand. Also suitable as a table for book cradle 5631. Sturdy steel tube construction with four casters (two are lockable) and matt-grey, plastic-laminated base board 86 x 60 x 3.2 cm (33.9 x 23.6 x 1.3 in.).

Dimensions (WxHxD): 922 x 490 x 680 mm  
 (36.3 x 19.3 x 26.8 in.)



5712

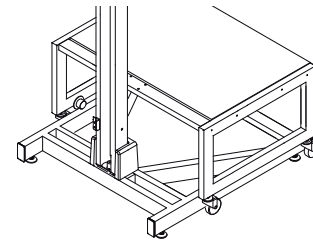

# D-Class for Pros

Digital photography has made image capturing much easier. New fields of application have been opened up, there are increased requirements for pictures.

Today's professional users achieve required results with cameras, which are smaller and lighter than those of the analogue era.

The creation of the new RD-System within the range of stands and lighting systems for image capturing is based on these observations. Dimensions and layout had to be adapted to the new situation. This has resulted in a stand with still "table-top" dimensions, but with superior convenience features and stability properties. There is a choice for units with manual or motorized height adjustment. The extensive use of high-precision profiled elements provides for exact adjustment travels and – in addition – has given the unit a new look.

For the first time in this application area Kaiser has designed lighting systems equipped with LED panels with specially selected components for high-quality and stable lighting.

The RD System offers professional equipment for professional users in industry, authorities, research and science – for all image capturing tasks with professional requirements.





## 5602/03 RSD Copy Stand

Column made of special aluminum multi-section tubing, matt black anodized, with cm and inch scales.

Camera carrier made of aluminum section, can be horizontally adjusted over approx. 16 cm (6.3 in.) with rack-and-pinion parallel guides. Left hand/right hand operation, two blocking screws prevent inadvertent changing of the adjusted position. Camera mounting plate tiltable by  $\pm 90^\circ$ . Connecting screw horizontally adjustable. Height adjustment with hand crank (5602) or motorized (5603).

Large non-reflecting matt grey base plate with printed grid, cm and inch scales. Feet adjustable in height. Spirit level.

Base plate (WxHxD): 680 x 38 x 570 mm  
(26.8 x 1.5 x 22.4 in.)

Height of column: 1.20 m (3.9 ft.)

Column cross section: 105 x 74 mm  
(4.1 x 2.9 in.)

Loading capacity: 8 kg (17.6 lbs.)

Camera mounting plate: 130 x 78 mm  
(5.1 x 3.1 in.)

Reversing mounting thread: 1/4" / 3/8"  
changeable

### 5602 RSD Copy Stand

Hand-cranked, rack-and-pinion height adjustment, additionally counter-balanced by a built-in coil spring. Blocking screw to stop accidental changing of height.

### 5603 RSD mot Copy Stand

Height adjustment motorized, with two speeds. Cable remote control. Constant adjustment speed, independent of load. Automatic end switch by photo sensors.

*Recommended lighting systems for the RD System copy stands are RB 5070 DX and the copy lighting units of the R1 system (from page 87).*

### 5622 RD Column

Same as 5602, but without base board.

### 5623 RD mot Column

Same as 5603, but without base board.



**5565**

### **RB 5070 DX Lighting Unit**

LED daylight lighting unit with two light banks for even and soft illumination. Each light equipped with 288 white high-CRI-LEDs. Lights can be dimmed separately or in conjunction. Dimmer has limit stop.

Lights can be tilted and adjusted in height. Vertical lamp arms tiltable with detents. Mounted with strong die-cast clamp bases, clamp width up to 48 mm (1.9 in.).

LED array: 2 x 288  
LEDs: High-CRI  
Color temperature: 5600 K  
Color rendition index: CRI > 85  
LED angle of radiation: 60°  
Power consumption: 2 x 22 W  
Illuminance on subject surface\*: 4000 lux

The RB 5070 DX lighting system is suitable for all RD and R1 System copy stands.

\* based on uniform illumination of a 24 x 16" flat subject

**5508**

### **Base Stand**

For converting RD system camera stands from table to free-standing models. Also suitable for R1 system camera stands and Kaiser base boards from 45 x 50 cm to 60 x 80 cm (17.7 x 19.7 in. to 23.6 x 31.5 in.). Height-adjustable feet.

Dimensions (WxHxD): approx. 580 x 510 x 595 mm (22.8 x 20.1 x 23.4 in.).

For picture see page 85.

**5624**

### **Wall Mount**

For RD / RD mot columns. Lower part with base, spirit level and compartment for power supply. Top section adjustable for vertical column positioning. Includes mounting material.

Distance wall – camera platform approx. 52-68 cm (20.5 x 26.8 in.).

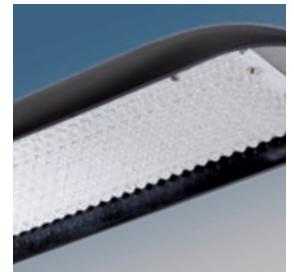

# eVisionary: The Copylizer

Everywhere in industry and administration, in medicine, science and research, in the entire area of communication and information technologies, where photos and other originals have to be copied, catalogued, archived, processed or transformed, there is one thing you need apart from the camera system of your own choice: a Kaiser copylizer. It provides reliable camera mounting and suitable lighting

- for photographic and electronic capturing of subjects of any kind, including three-dimensional subjects,
- for electronic documentation using digital or analogue camera systems,
- for capturing documents, logos, symbols, photos and drawings for further processing in DTP systems or for further use in video conferences or online networks,
- for reproducing and documenting X-ray films, large format slides, silhouetted subjects and transparent objects,
- as a video presenter in schools and universities, at training courses and meetings, in advertising, industry, medical imaging and for use by military and public authorities,
- for integration into evaluation systems for quality testing and monitoring in industry labs.

The stands can be used either with or without the respective side lighting units, as there are mounting provisions on all stands.





**5211/12/32**  
**Copylizer eVision exe.cutive/  
eVision exe.cutive HF**

Camera stand with integrated transmitted light source. Illumina base with four 13 W daylight fluorescents 5400 K, illuminated area 43 x 35 cm (16.9 x 13.8 in.). Illuminance 3300 cd/m<sup>2</sup>. Mounting fixtures for optional side lighting unit. Height-adjustable feet. Base with spirit level. 70 mm (2.8 in) wide high-stability, vibration-resistant column made of special aluminum tubing, matt black anodized, with cm and inch scales. Hand-crank operated height adjustment of camera arm by friction drive on plastic bearings. Weight compensation by integrated coil spring, RTP camera arm with horizontally adjustable camera platform, camera body positioning device and interchangeable 1/4" and 3/8" threads.

Illumina base (WxD): 63 x 55 cm  
(24.8 x 21.7 in.)

Column height: 1 m (40 in.)

Max. load: approx. 4 kg (8.8 lbs.)

Mains cord: 2.5 m (6.5 ft.)

**5211:** Mains frequency operation.  
Not available in 120 volt.

**5212:** Illumina base with high-frequency operation system (approx. 40 kHz) for flicker-free operation, especially important for use with digital scanning cameras.

**5232:** Illumina base with high-frequency operation system, dimmable.

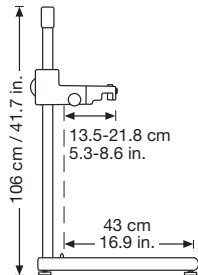



**5276/77/80/81**  
**RB 4.36 HF/RB 4.55 HF**  
**Copolyzer Lighting Unit**

Lighting unit consisting of two light banks and lamp arms. Lamps can be tilted, shifted and adjusted in height. Vertical arms with height markings, tiltable with detents.

Connects to and is operated via copolyzer illumina base. Lights with high-gloss inside reflectors for high light output plus filter holder and diffusion screen. High-frequency operating system (approx. 40 kHz) for universal use with digital applications.

**5276:** Lamps: 2 x 36 W each, daylight fluorescent lamp 5400 K, CRI = 90-100, light emitting area approx. 50 x 21 cm (19.7 x 8.3 in.)

**5277:** same as 5276, but with dimmable lights

**5280:** Lamps: 2 x 55 W each, daylight fluorescent lamp 5400 K, CRI = 90-100, light emitting area approx. 64 x 21 cm (25.2 x 8.3 in.)

**5281:** same as 5280, but with dimmable lights

**5270**  
**RB 2.36 Copolyzer Lighting Unit**

Lighting unit consisting of two light banks and lamp arms. Lamps can be tilted and adjusted in height, with filter holders and diffusion screens. Vertical arms with height markings, tiltable with detents. Connects to and is operated via copolyzer illumina base.

Lamps: 1 x 36 W each, daylight fluorescent lamp 5400 K, CRI = 90-100, light emitting area approx. 50 x 21 cm (19.7 x 8.3 in.)

**5256**  
**Clamp Base**

For attaching lighting units 5267/5270/5276/5277/5280/5281 to regular boards up to 48 mm (1.9 in.) thickness.  
 2 pieces.



## 5241/42/62 Illumina Base

Can be combined with components of the Kaiser R1 system. Trans-illuminator with four 13 W daylight fluorescent lamps 5400 K, illuminated area approx. 43 x 35 cm (16.9 x 13.8 in.), illuminance approx. 3300 cd/m<sup>2</sup>. Optional side lighting units can be attached, connected and operated. Height-adjustable feet. Base with spirit level for 70 mm (2.8") wide column.

Outside dimensions (WxD):  
approx. 63 x 55 cm (24.8 x 21.6 in.)  
Mains cord: approx. 2.5 m (6.5 ft.)

**5241:** Mains frequency operation.  
Not available in 120 volts.

**5242:** High-frequency operation (approx.  
40 kHz) for universal use with all  
digital applications.

**5262:** same as 5242, lights dimmable.



2136,  
2477



## 5292 Pressure Plate

For 5211/12/32 Copylizers and 5241/42/62 Illumina Bases.

Made of high-quality crystal glass to press „wavy“ originals. Can be fitted to the hinge of the illumina base and is easily lifted. With adjustable stop guides.

## 5294 Metal Plate

For 5211/12/32 Copylizers and 5241/42/62 Illumina Bases.

For holding originals with magnetic holders (four included) and as a protective cover of the acrylic glass plate. Can be fitted to the hinge of the illumina base and is easily lifted. With printed grid for positioning and adjustable stop guides.





**5205-06**  
**Copylizer eVision ini.tial/  
 eVision ini.tial HF**

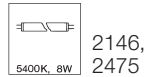
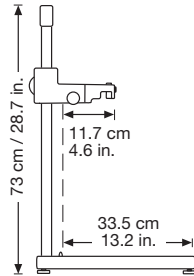

Camera stand with integrated trans-illuminator. Illumina base with four 8 W daylight fluorescents 5400 K, illuminated area 20 x 18 cm (7.9 x 7.1 in.). Illuminance 4600 cd/m<sup>2</sup>. Mounting fixtures for optional side lighting unit. Height-adjustable feet. 70 mm (2.8 in.) wide high-stability, vibration-resistant column made of special aluminum tubing, matt black anodized, with cm and inch scales. Hand-crank operated height adjustment of camera arm by rack-and-pinion drive and additional fine drive. Weight compensation by integrated coil spring, RA 101 camera arm with camera body positioning device and interchangeable 1/4" and 3/8" threads. Illumina base (WxD): 32 x 45 cm (12.6 x 17.7 in.)  
 Column height: 67 cm (26 in.)  
 Max. load: approx. 4 kg (8.8 lbs.)  
 Mains cord: 2.5 m (6.5 ft.)

**5205:** Mains frequency operation.  
 Not available in 120 volt.  
**5206:** Illumina base with high-frequency operation system (approx. 40 kHz) for flicker-free operation, especially important for use with digital scanning cameras.



**5267**  
**RB 2.18N HF**  
**Copylizer Lighting Unit**

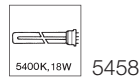

Lighting unit for 5205 and 5206 Copylizer, consisting of two lights and holding arms. Lamps can be tilted and adjusted in height, vertical arms tiltable with detents.  
 Lamps: 1 x 18 W each, daylight fluorescent lamp 5400 K. High-frequency operation (approx. 40 kHz).

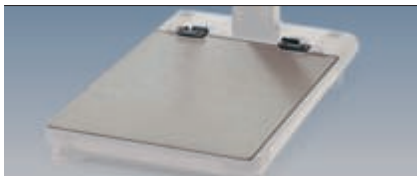

**5298**  
**Metal Plate**

For 5205 and 5206 Copylizer. For holding originals with magnetic holders (four included) and as a protective cover of the acrylic glass plate. Can be fitted to the hinge of the illumina base and is easily lifted.

# The Power of Possibilities

The R1 system is a powerful system. It is universal, sophisticated, flexible, versatile, multi-functional and adaptable.

It is designed for professional users and dedicated photographers and offers high stability, angular precision and quality workmanship.

It is ideal for use with conventional and digital camera systems up to 4 kg (8.8 lbs.) total weight and offers a vast range of components and accessories.

Base boards of various sizes, columns of different height, camera arms with a variety of adjustment options, lighting units with various lamps and reflectors, working at different power levels, with various mounting and adjustment options make it possible to adapt the units to individual requirements.

This system is completely modularized and therefore allows also customized configurations.





## 5512 RSX Camera Stand

Big non-reflecting matt grey base plate with printed grid, cm and inch scale. Feet adjustable in height. Spirit level in column base. Especially wide and low-vibration column made of matt black anodized aluminium tubing with cm and inch scale. Height adjustment with hand crank and rack with extra weight compensation by integrated coil spring. Blocking screw to stop accidental changing of height. RTX camera arm with adjustable and pivotable camera holder. Camera can be mounted forwards or backwards. Camera platform can be horizontally adjusted by fine mechanism. Interchangeable  $1/4''/3/8''$  mounting thread. Including dust hood.

Base plate: approx. 600 x 500 x 32 mm  
(23.6 x 19.7 x 1.3 in.)

Height of column: 1.20 m (4 ft.)

Loading capacity: 3.5 kg (7.7 lbs.) max.

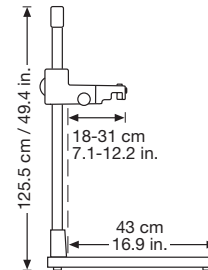

## 5513 RS 10 Camera Stand

Large non-reflecting, matt grey base board with a printed fine grid and cm/inch scale. Height-adjustable feet. Spirit level integrated into the base. Especially wide, virtually vibration-free column made of matt black anodised aluminium section tube with cm/inch scale. Hand-cranked, rack-and-pinion height adjustment, additionally counter-balanced by a built-in scroll spring. Locking screw prevents inadvertent changing of the adjusted height. RTP camera arm (5524) with precision, parallel-guided horizontal adjustment over approx. 8 cm (3.1 in.). Reversible mounting thread  $1/4''/3/8''$ . Including dust cover.

Base board (WxHxD): approx. 600 x 32 x 500 mm (23.6 x 1.3 x 19.7 in.)  
Column height: approx. 1 m (39 in.)  
Maximum load: 4 kg (8.8 lbs.)

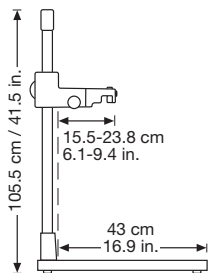

## 5508 Base Stand

For converting R1 system and RD system camera stands from table to free-standing model. Also suitable for all Kaiser baseboards from 45 x 50 cm to 60 x 80 cm (17.7 x 19.7 in. to 23.6 x 31.5 in.). Height-adjustable feet. Slide-in compartment for control box of optional lighting unit. Dimensions (WxHxD): approx. 580 x 510 x 595 mm (22.8 x 20.1 x 23.4 in.)





## 5510–11 RS 1 Camera Stand

Non-reflecting matt gray base board with printed fine grid. Feet adjustable in height. Spirit level in column base. Extra-wide and extremely vibration-resistant column of dull black anodized aluminium tubing with cm and inch scales. Hand crank-operated height adjustment by friction drive on plastic bearings. Weight compensation by roll-off spring mechanism.

Base board: approx. 450 x 500 x 28 mm  
(17.7 x 19.7 x 1.1 in.)

Column height: approx. 1000 mm (39.4 in.)

### 5511 RS 1 Camera Stand

With RT 1 copy and titling arm with two camera fastening points. Interchangeable threaded bush  $1/4''/3/8''$ . Camera carrier pivots and slides horizontally. Maximum load: 3 kg (6.6 lbs.)

### 5510 RS 1 Camera Stand

With RA 1 camera arm with interchangeable threaded bush  $1/4''/3/8''$  and camera adjustment device.

Maximum load: 4 kg (8.8 lbs.)

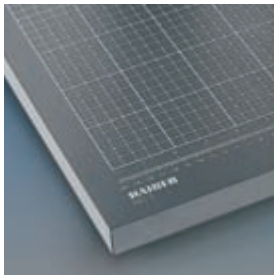
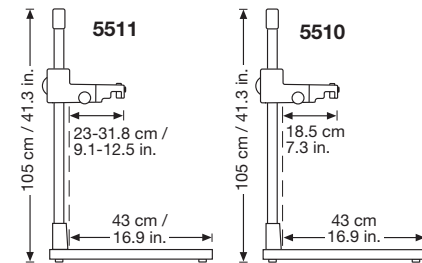

## 5507 RS 1 „microdrive“ Camera Stand

Same as RS 1 Camera Stand (5510), but with hand-cranked, rack-and-pinion height adjustment, additionally counter-balanced by a built-in scroll spring. Additional fine drive with 1:6 step-down transmission for super-fine adjustment. Locking screw prevents inadvertent changing of the adjusted height.



**5589-90**  
**RB 5055 HF Lighting Unit**

Cold-light unit with two light banks, each one fitted with two daylight fluorescent lamps, high-gloss inside reflectors and high-frequency operating system. Lights can be tilted and shifted. Horizontal lamp arms can be adjusted continuously in height. Vertical lamp arms with height markings, tiltable with detents. Mounted with strong die-cast clamp bases, clamp width up to 48 mm (1.9 in.). Separate control box.

Lamps: 4 x 55 watt  
Color temperature: 5400 K  
Color rendition index: CRI = 90-100 (1A)  
Light emitting area: 64 x 21 cm  
(25.2 x 8.3 in.)

**5589:** continuously dimmable down to 10%  
**5590:** not dimmable



3454



**5591/95**  
**RB 5003 UV / RB 5003 UV-HF**  
**Lighting Unit**

UV lighting unit with two light banks, each one fitted with three UV-A fluorescent lamps for applications in UV and fluorescence photography. Lights can be tilted and shifted. Horizontal lamp arms can be adjusted continuously in height. Vertical lamp arms with height markings, tiltable with detents. Mounted with strong die-cast clamp bases, clamp width up to 48 mm (1.9 in.). Separate control box.

Lamps: 6 x 18 watt UV-A  
Wave length: 366 nm  
Light emitting area: 64 x 21 cm  
(25.2 x 8.3 in.)

**5591:** Mains frequency operation  
**5595:** High-frequency operation  
(approx. 40 kHz)

**5569**  
**UV-A Fluorescent Lamp**

18 watt, average service life 8000 hours,  
G 13 socket, length 590 mm. 1 piece.



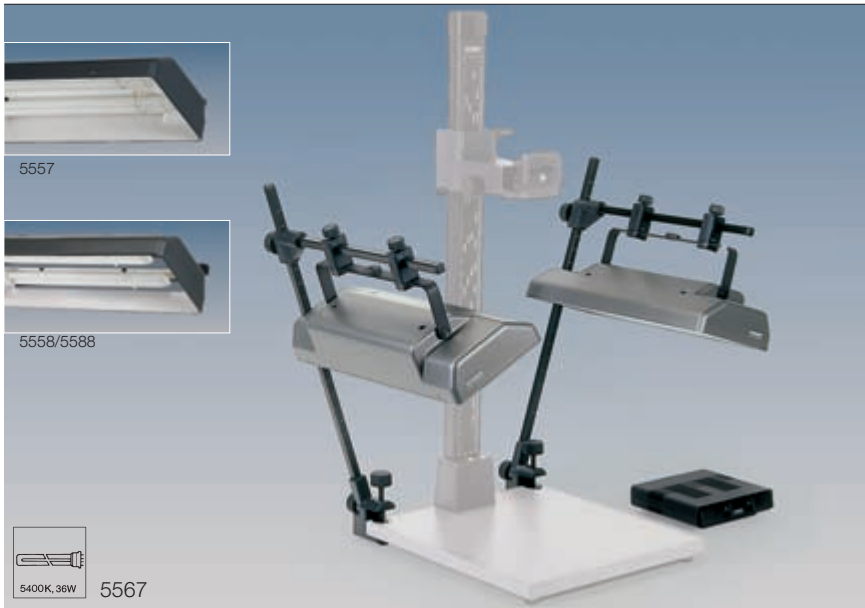

### 5557-58/5588 RB 5004/RB 5004 HF Lighting Unit

Cold-light unit with two light banks, each one fitted with two daylight fluorescent lamps. Lights can be tilted and shifted. Horizontal lamp arms can be adjusted continuously in height. Vertical lamp arms with height markings, tiltable with detents. Mounted with strong die-cast clamp bases, clamp width up to 48 mm (1.9 in.). Separate control box.

Lamps: 4 x 36 watt  
 Color temperature: 5400 K  
 Color rendition index: CRI = 90-100 (1A)  
 Light emitting area: 50 x 21 cm  
 (19.7 x 8.3 in.)

**5557:** Mains frequency operation.  
 Not available in 120 V.

**5558:** High-gloss inside reflectors and high-frequency operating system (40 kHz)

**5588:** High-gloss inside reflectors and high-frequency operating system (40 kHz), continuously dimmable down to 10%.



### 5556 RB 5000 DL Lighting Unit

Cold-light unit with two light banks, each one fitted with one daylight fluorescent lamp. Lights can be tilted. Horizontal lamp arms can be adjusted continuously in height. Vertical lamp arms with height markings, tiltable with detents. Mounted with strong die-cast clamp bases, clamp width up to 48 mm (1.9 in.).

Lamps: 2 x 36 watt  
 Color temperature: 5400 K  
 Color rendition index: CRI = 90-100 (1A)  
 Light emitting area: 50 x 21 cm  
 (19.7 x 8.3 in.)

**5582/92  
Filter Holders**

Guiding rails to attach slide-in filters to Kaiser camera stand lighting units. 2 pairs.

**5582:** For reflector size 50 x 21 cm (19.7 x 8.3 in.) (5556-58/5588)

**5592:** For reflector size 64 x 21 cm (25.2 x 8.3 in.) (5589-91/5595)

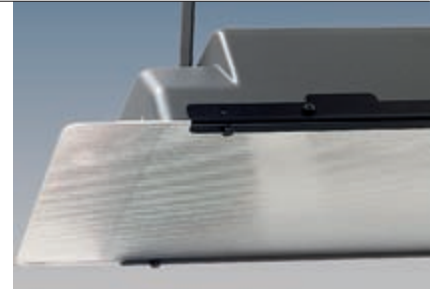

**5583/93  
Diffusion Screens**

Fine-structured acrylic glass. Mounts to camera stand lighting units in connection with 5582/92 Filter Holders. 2 pieces.

**5583:** For reflector size 50 x 21 cm (19.7 x 8.3 in.) (5556-58/5588)

**5593:** For reflector size 64 x 21 cm (25.2 x 8.3 in.) (5589-91/5595)

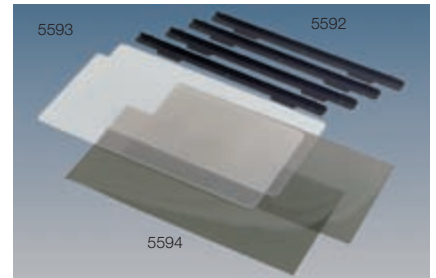

**5594  
Polarizers**

Mounts to lighting units 5556-58, 5588-91, 5595 in connection with 5582/92 Filter Holders. 2 pieces.

Dimensions: 64 x 21 cm (25.2 x 8.3 in.), can be trimmed to 50 x 21 cm (19.7 x 8.3 in.)

**Fluorescent Lamps**

Replacement lamps for rePRO, Copylizer, R1 and R2 system. Daylight fluorescent tubes. Color temperature 5400 K, light color 12, color rendition index CRI = 90-100. Average service life: approx. 8000 hours with constant color temperature. For critical requirements on color-correct reproduction replace fluorescents replace in sets.



	Code	Power	Socket	Length (w/o pins) mm/in.	Tube-ø (mm)	Qty. (pieces)	fits
Tube shape	<b>2146</b>	8 W	G 5	288 mm	16	1	5205-06
	<b>2475</b>	8 W	G 5	288 mm	16	4	5205-06
	<b>2136</b>	13 W	G 5	517 mm	16	1	5211/12/32/41/42/62
	<b>2477</b>	13 W	G 5	517 mm	16	4	5211/12/32/41/42/62
Dulux	<b>5458</b>	18 W	2 G 11	217 mm	2 x 17.5	1	5267, 5464, 5304
	<b>5567</b>	36 W	2 G 11	411 mm	2 x 17.5	1	5270, 5276-77, 5556-58, 5588
	<b>2414</b>	55 W	2 G 11	533 mm	2 x 17.5	1	5617
	<b>2487</b>	55 W	2 G 11	533 mm	2 x 17.5	4	5617
	<b>3454</b>	55 W	2 G 11	533 mm	2 x 17.5	1	5280-81, 5589-90, 5656-57



**5552**  
**RB 300 Lighting Unit**

With two convection-cooled halogen lights. Lights can be tilted and shifted. Horizontal lamp arms can be adjusted continuously in height. Vertical lamp arms with height markings, tiltable with detents. Mounted with strong die-cast clamp bases, clamp width up to 48 mm (1.9 in.). Lights can be switched separately. Lamps included.

Lamps: 2 x 300 Watt  
Color temperature: 3200 Kelvin  
Cord: 2 x 4 m (2 x 13.1 in.)

**3038/3058**  
**Halogen Lamp**

For RB 300 Lighting Unit.

**3038:** 300 W, 3200 K, 7300 lm, average service life approx. 75 hours, 1 piece.

**3058:** 300 W, 3400 K, 8500 lm, average service life approx. 15 hours. 1 piece.



**5554**  
**RB 104 Lighting Unit**

With four reflector lights with E 27 screw-in socket, suitable for photofloods up to 250 watt. Lights can be switched separately. Lights can be tilted and shifted. Horizontal lamp arms can be adjusted continuously in height. Vertical lamp arms with height markings, tiltable with detents. Mounted with strong die-cast clamp bases, clamp width up to 48 mm (1.9 in.) Reflector-diameter: approx. 14 cm (5.5 in.). Cord: 2 x 2 m (2 x 6.5 in.).  
Supplied without lamps.

Recommended lamps, 1 piece:

**4356:** Opal lamp 75 W, 3000 K

**3124:** Opal lamp 150 W, 3000 K

**3130:** Photoflood 250 W, 3000 K  
(without reflector)

**3128:** Reflector lamp 150 W, 3200 K

**3110:** Energy saving lamp 25 W, 6400 K

**5563**  
**RB 3 Lamp Fixtures**



3128

For use with 5560 Lamp Arms.  
Lamps: 2 x 250 W max., E 27  
Cord: 2 x 2 m (6.5 ft.) with cord switch  
2 pieces, without lamps.



**5571**  
**Flash/Light Fixtures**

For fastening conventional flashes or lights with accessory foot or 1/4" mounting thread to holding rods with 16 mm (.63 in.) square tube, e.g. the 5560 Lamp Arms.



**5560**  
**Lamp Arms**

Complete set for two or four lights. The arms are adjustable in height and angle and can be fitted with 5563 Lamp Fixtures and with 5571 Flash/Light Fixtures. Clamp attachment on boards up to 48 mm (1.9 in.).



**5549**  
**Extraneous Light Protector**

Completely shut tent for light-tight shielding of an image capturing work station. Suitable for Copylizer and R1 system copy stands with mounted copy lights. Black teflon-coated fabric, antistatic and lintfree. Front zipper.

Includes mounting rods (WxD: 85 x 80 cm / 33.5 x 31.5 in.), that are attached to the upper end of the column.

Suitable for 1 m (39.4 in.) and 1.20 m (47.2 in.) columns.



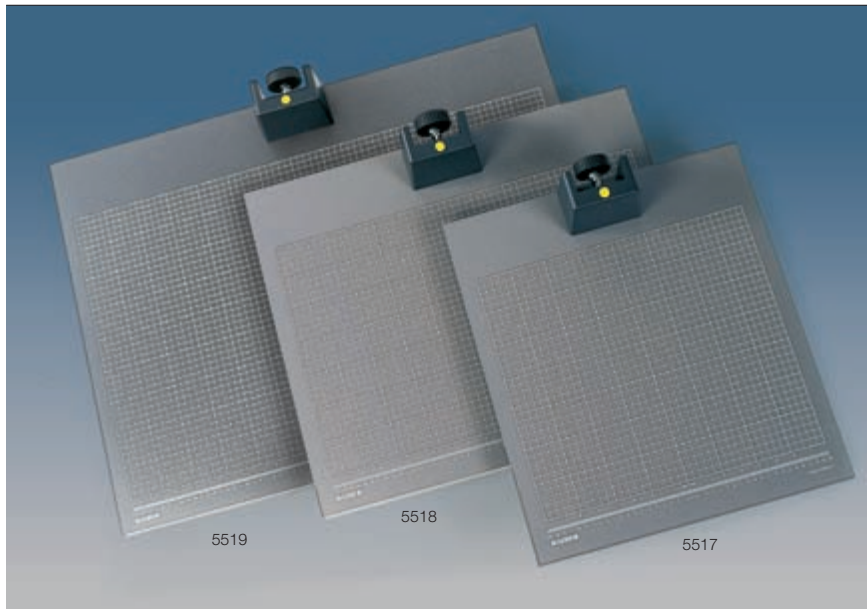

## 5517-19 Base Board

Matt grey laminated base board with mounted base for attaching column. Printed fine grid with cm and inch scale. Spirit level in base. Individually height-adjustable feet.

Dimensions (WxDxH):

**5517:** approx. 450 x 500 x 28 mm  
(17.7 x 19.7 x 1.1 in.)

**5518:** approx. 600 x 500 x 32 mm  
(23.6 x 19.7 x 1.3 in.)

**5519:** approx. 800 x 600 x 32 mm  
(31.5 x 23.6 x 1.3 in.)

(Dimensions excluding base and feet)

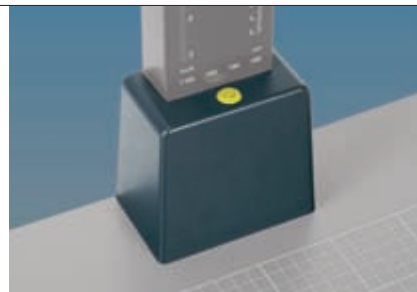

## 4427 Column Base

For mounting a column with 70 x 35 mm (2.8 x 1.4 in.) cross section to table boards or work plates. Built-in spirit level.

Includes fastening screw for the column and installation material (metal counter plate and four M6x40 screws for boards from 28 to 32 mm (1.1 x 1.3 in.) thickness).

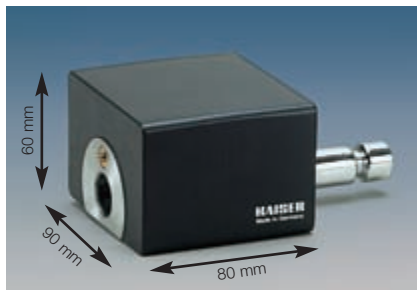

## 4455 Extension Arm

To extend the camera arm mount. Required for capturing large originals. This increases the distance between the optical axis of the camera lens and the column base by 80 mm (3.2 in.), if the extension arm is attached between the mount and the camera arm.

## 4473-78/4408-09 Column

Wide and extremely vibration-resistant column of aluminium tubing with dull black anodized surface and cm and inch scales. With mount (4478 with two mounts) and fastening mechanism for camera arms. Height adjustment by hand crank. Cross-sectional dimensions of the column: 70 x 35 mm (2.8 x 1.4 in.)

- 4473:** Height adjusted by friction gear with plastic bearings, without weight compensation, height 1 m (40 in.)
- 4474:** Height adjusted by friction gear with plastic bearings, weight compensated by built-in roller spring, height 1 m (40 in.)
- 4475:** Height adjusted by gear rack with weight compensation by built-in roller spring, additional 1:6 fine drive. Locking screw for fixing height adjustment. Height 1 m (40 in.)
- 4476:** Same as 4475, but without fine drive.
- 4478:** With two mounts for camera arms, each equipped with locking screw for fixing height adjustment. Height adjustment by gear rack, upper mount with weight compensation by built-in roller spring. Height 1 m (40 in.).
- 4408:** Height adjusted by gear rack, weight compensated by built-in roller spring, locking screw for fixing height adjustment. Height 1.2 m (47 in.)
- 4409:** Height adjusted by friction gear with plastic bearings, weight compensated by built-in roller spring, locking screw for fixing height adjustment. Height: 1.5 m (60 in.)



## 4412 Wall Mount

Sturdy wall mount for all R1 system columns. Wall mounting with 6 screws. Upper part adjustable for absolutely vertical position. Lower part with base and spirit level. Entire height with 1 m column: 1.16 m (3 ft. 10 in.). Distance wall - front edge of mount (without camera arm): approx. 25 cm (9.8 in.) Supplied with screws and dowels.





**5522  
RTX Camera Arm**

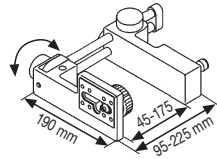

Camera mount with spirit level for fine adjustment. Turns  $\pm 180^\circ$  and can be fixed in every position. Camera can be mounted on front or rear. Camera mount horizontally adjustable with fine adjustment.

Interchangeable  $1/4''/3/8''$ . mounting thread.



**5521  
RT 1 Copy and Titrng Arm**

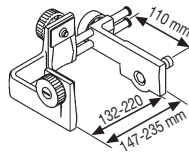

Camera fastening points for horizontal and upright formats, with interchangeable threaded bush  $1/4''/3/8''$ . and rubber rests.

A parallel guide makes the camera platform longitudinally adjustable, and it can be locked in any position. The entire copy and titling arm is tiltable to allow for reproduction of vertical subjects.



**5524  
RTP Camera Arm**

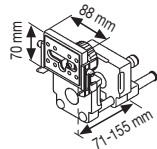

Horizontally adjustable via parallel guides to change the distance to the column. Moves approx. 8 cm (3.1 in.) back and forth. Camera positioning device, adjustable to different camera bodies.

Reversible mounting thread  $1/4''/3/8''$ .



**5520  
RA 1 Camera Arm**

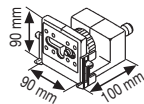

Device for adjusting the camera, can be set to different camera bodies.

Interchangeable  $1/4''/3/8''$  mounting thread.



**5523**  
**RA 101 Camera Arm**

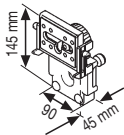

Specially suitable for cameras with large distance between tripod hole and optical axis of lens. Device for adjusting the camera, settable to different camera bodies.

Interchangeable 1/4" / 3/8" mounting thread.



**5539**  
**RLR Camera Arm**

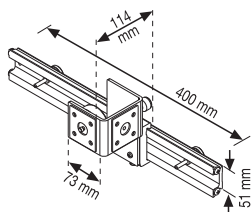

Camera platform can be shifted horizontally to left or right and can be blocked in any position. Adjustable stops for end position of camera. Camera can be mounted for horizontal or vertical format. Especially suitable for use with 5904 Book Holder when copying books page by page.

Camera platform moves approx. 15 cm (6 in.) from center to each side.



**5540**  
**2CC Camera Arm**

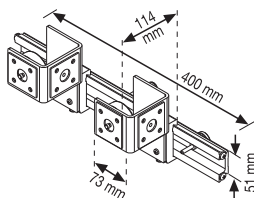

Similar to 5539, but with two camera carriers which can be adjusted separately. For mounting two cameras, e.g. for comparison shots.



**5531**  
**Focusing Stage**

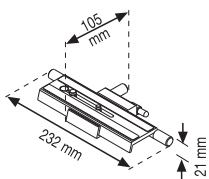

Extremely flat focusing stage with fine drive with spindle. Rapid adjustment with single lever lock. Locking screw. Setting range 120 mm (4.7 in.) with mm scale. Large camera platform with non-slip surface and interchangeable 1/4" / 3/8" mounting thread. 1/4" / 3/8" tripod thread. Made of black anodized aluminum.

Two focusing stages can be combined for crossed stanges.



# Heavy Metal

Some working environments and applications require primarily one thing: robustness.

Testing stations in manufacturing, design and quality assurance in industrial production, special climatic conditions or the need to adapt additional equipment sometimes require device properties that exceed the usual standards.

The Vertical Stand is a unit that can cope with these requirements. It is kind of a „Heavy Metal“ version of R1 system stand with a metal base board, that can be completed with a R1 system camera arm (see page 94 - 95).



**4405-06**  
**Column for Vertical Stand**

Wide and extremely vibration-resistant column of aluminium tubing with dull black anodized surface and cm and inch scales. With mount and fastening mechanism for camera arms. Hand-crank operated height adjustment and gear rack, with weight compensation by built-in roller spring, additional 1:6 fine drive. Locking screw for fixing height adjustment. Cross-sectional dimensions (WxD): approx. 70 x 35 mm (2.8 x 1.4 in.). Includes premounted column base with spirit level.

Suitable camera arms: RA 101 (see page 95) or other R1 system camera arms.

**4405:** Height: 63 cm (24.8 in.)

**4406:** Height: 100 cm (39.4 in.)



**5503**  
**Metal Base Plate for Vertical Stand**

Dark gray finished steel plate with printed fine grid and cut-out section 120 x 120 mm (4.7 x 4.7 in.) for insertion of either a metal cover or a glass insert for transmitted light shooting. Receptacle for accessories with 16 mm (0.6 in.) standard spigot. Height-adjustable feet. Includes metal and glass inserts.

Dimensions (WxD): 320 x 420 mm (12.6 x 16.5 in.), thickness of plate: 8 mm (0.3 in.), weight (without insert): approx. 7.5 kg (16.5 lbs.).

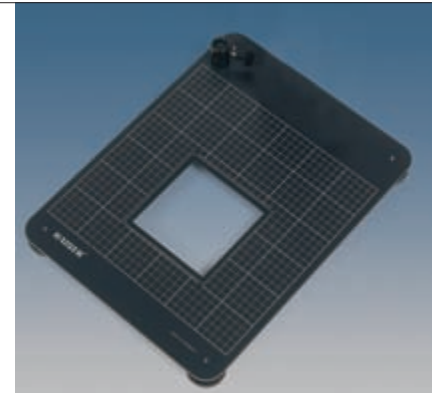

**5040**  
**„Magic Arm“ Hinged Bracket**

To mount and individually align cameras, lights and accessories. Mounted with reversible thread adapter on tripods and clamps with a 16 mm (0.6 in.) sleeve. Mounting platform with sliding 1/4". Camera screw, 3/8". conversion thread and reflector umbrella mount. Reversible thread adapter with 1/4" and 3/8" internal thread and with ball-and-socket joints at both ends. Both ball-and-socket joints and the middle joint are released and tightened by a central locking disk. Max. load (in horizontal position): 4 kg (8.8 lbs.).



# Lightweight Class



Even though cameras are growing smaller and lighter – the stability requirements remain unchanged.

Camera stands and lighting units of the R2 family are „light“ versions of the R1 system. Designed for light-weight cameras, their dimensions and stability are related to the respective needs.

The stands are not only for the majority of digital cameras, compacts and smaller SLRs, but are also suitable for industrial CCD and CMOS cameras.

There is also a range of suitable lighting units: LED panels, high frequency fluorescents, but also basic tungsten lamp lighting.

## 5411 RS 2 XA Camera Stand

Non-reflective matt grey base board with printed fine grid and cm/inch scale. Matt-black anodised aluminum section tube column with cm/inch scale. Hand-cranked height adjustment by friction drive in plastic bearings. With horizontally adjustable camera arm to change the distance to the column, moves approx. 7 cm (2.7 in.) back and forth. 1/4" mounting thread.

Base board (WxHxD): approx. 400 x 25 x 500 mm (15.7 x 1 x 19.7 in.)

Column height: approx. 76 cm (30 in.)

Maximum load: 1.5 kg (3.3 lbs.)

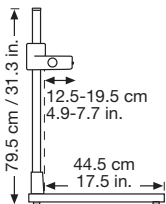

## 5450 RB 2 Lighting Unit

With four tiltable and adjustable reflectors on mounting arms which are in turn tiltable and adjustable in height. Lights can be switched on separately.

Suitable lamps: 4 x 150 W max.

Clamp attachment for thickness up to 48 mm (1.8 in.).

Cords: 2 x 1.7 m (5 1/2 ft.)

Supplied without lamps.

Suitable lamps, 1 piece:

**4356:** Opal lamp 75 W, 3000 K, 1100 lm, average service life 100 hours, E27.

**3124:** Opal lamp 150 W, 3000 K, 2500 lm, average service life 100 hours, E27.

## 5534 Focusing Stage

For exact camera positioning for close-up, macrophotography and copying.

See page 172 for detailed description.





---

**5465**  
**RB 5020 DS Lighting Unit**

LED daylight lighting unit with two light banks for even and soft illumination. Light banks with 192 white high CRI LEDs each. Lights can be dimmed individually or synchronized. Dimmer has OFF position.

Lights are tiltable and adjustable in height. Angle of vertical arms adjustable by lock joint. Mounted with strong die-cast clamp bases. Clamp width up to 48 mm (1.9 in.).

Colour temperature: 5600 Kelvin  
Colour rendition index: CRI > 85  
Angle of radiation: 60°



---

**5464**  
**RB 218N HF Lighting Unit**

Cold light lighting unit with two small light banks with one daylight fluorescent each. High-frequency operating system (approx. 40 kHz). Main leads with cord switches. Lights are tiltable and adjustable in height. Angle of vertical arms adjustable by lock joint. Mounted with strong die-cast clamp bases. Clamping width up to 48 mm (1.9 in.).

Lamps: 2 x 18 watt  
Color temperature: 5400 K  
CRI = 90-100 (1A)

---

**5458**  
**Replacement Lamp for RB 218N HF**

Dulux fluorescent lamp 18 W, 5400 K, Light color 12, CRI = 90-100 (1A), average service life 8000 hrs., socket 2 G 11, length 217 mm (8.5 in.). 1 piece.

## 5304 R2N CP Image Capturing Set

Portable camera stand with RB 218N HF Lighting Unit (5464).

Non-reflective matt grey base board with printed fine grid and cm/inch scale. Matt-black anodised aluminium section tube column with cm/inch scale. Hand-cranked height adjustment by friction drive in plastic bearings. With horizontally adjustable camera arm to change the distance to the column, moves approx. 7 cm (2.8 in.) back and forth. 1/4" mounting thread. Column folds down on baseboard.

Base board (WxD): approx. 400 x 250 mm (15.7 x 1 x 16.5 in.)

Column height: approx. 60 cm (23.6 in.)  
Maximum load: 1.5 kg (3.3 lbs.)

RB 218N HF Lighting Unit with high frequency operating system. Two small light banks, each equipped with a cold light fluorescent lamp, tiltable and adjustable in height. Angle of vertical arms adjustable by lock joint. Mounted with strong die-cast clamp bases. Clamp width 48 mm (1.9 in.).

Lamps: 2 x 18 watt  
Color temperature: 5400 K  
CRI: 90-100

Comes in padded carrying case 67 x 47 x 23 cm (26.4 x 18.5 x 9.1 in.) with handle and wide shoulder strap.

## 5301 RS 2 CP Camera Stand

same as 5304, but without lighting unit.

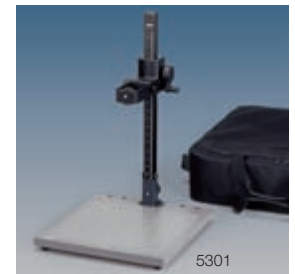
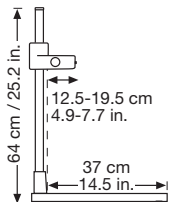

# The Story of „Repro the Kid“



Is it really possible to make something that is innately rugged, sturdy and as vibration-resistant as possible still smaller, lighter and more „desktop-suitable“? Individuals with very small budgets and very small cameras have asked for that. And out of that request came the „reprokid“ - a small, light-weight, compact stand for small, light-weight, compact cameras.

This unit is „good enough“ for wherever the requirement is for minimum space and light weight. And really: even the price has moved accordingly.





**5360**

### „reprokid“ Camera Stand

Super-compact camera stand for small, lightweight cameras (digital compacts, CCD cameras, etc.). Non-reflective, matt grey base board. Column with cm/inch scale. Height-adjustable camera arm. 1/4" mounting thread.

Base board (WxHxD): 32 x 1.9 x 38 cm  
(12.6 x 0.7 x 15 in.)

Column height: 59 cm (23.2 in.)

Max. load: 1 kg (2.2 lbs.)

Includes lighting unit with two E 27 screw-in mounts for lamps up to 250 Watt (supplied without lamps).

Power cables: 2 x 2.5 m (8 ft. 2 in.), with cord switch.

Suitable lamp:

**3128:** Reflector lamp 150 W, 3200 K

**5361**

### „reprokid“ Camera Stand

Same as 5360, but without lighting unit.

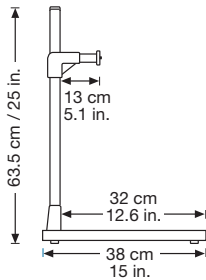

# Hold the Post!

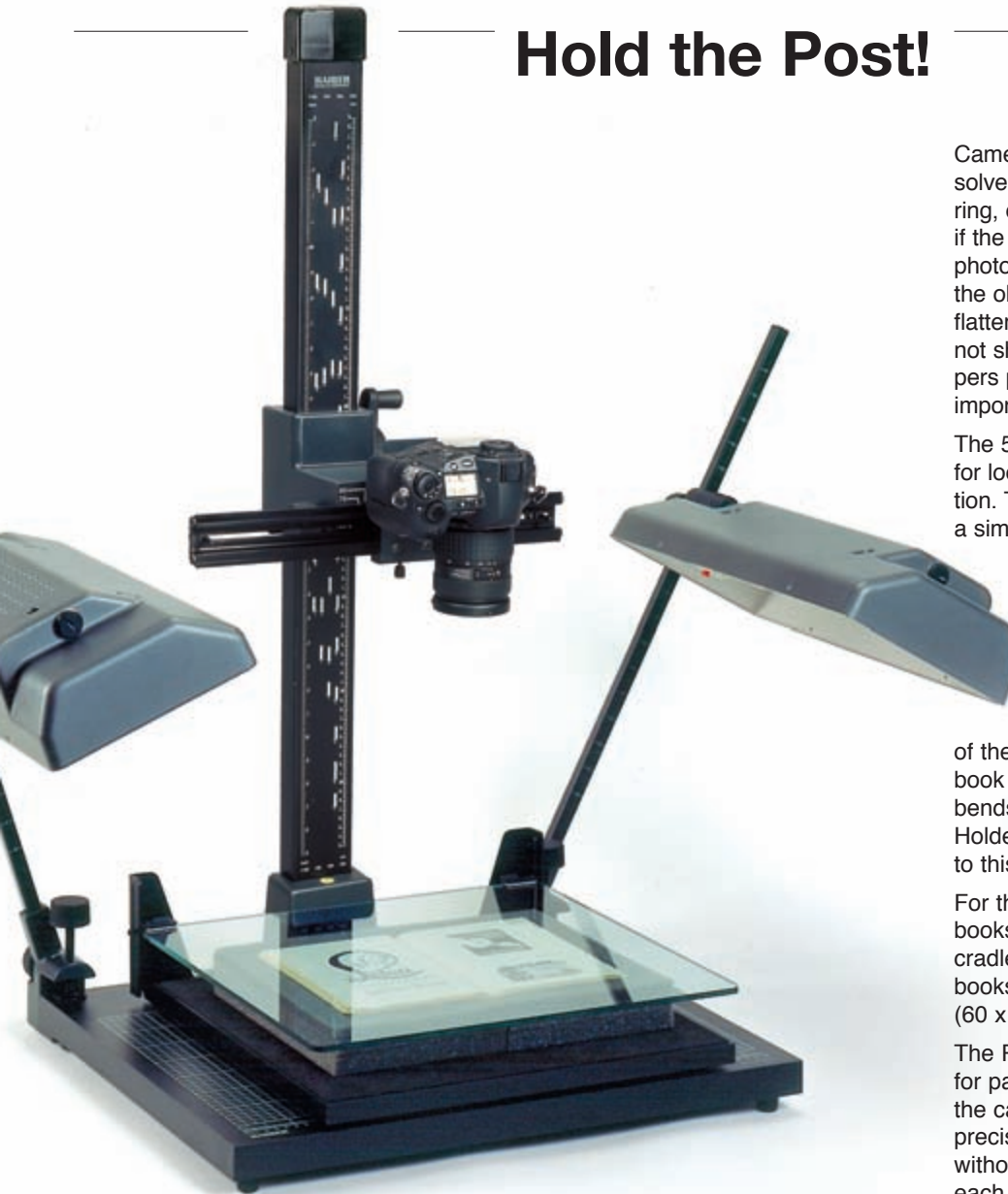

Camera stands and lighting units can solve almost all problems when capturing, digitizing or copying originals. But if the original itself is „reluctant“, if the photo album refuses to stay open or if the old wavy photograph needs to be flattened or the press clipping should not shift, then the little (or bigger) helpers presented here, are of great importance.

The 5901 Copy Plate is a reliable tool for locating originals in a certain position. The 5903 Document Holder does a similar job for smaller originals and allows the possibility to position the original at any desired angle towards the camera.

Especially when copying opened books or albums you have to fight the stubbornness of the inanimate. Normally an open book will not lie flat and each page bends differently. The Kaiser Book Holder is a simple but efficient solution to this problem.

For the professional reproduction from books there is also classical book cradle accepting even large-sized books up to 23.6 x 17.7 in. (60 x 45 cm) open format.

The RLR Camera Arm should be used for page-by-page copying because the camera can always be positioned precisely over the corresponding page without having to move the book for each shot.

## 5904 Book Holder

43 x 41 cm (16.9 x 16.1 in.) sized, solid base plate with non-slip coating on top non-slip feet underneath. 6 mm (0.2 in.) thick glass plate, foldable and variable in height up to maximum 95 mm (3.7 in.).

Incl. 8 preformed foam elements for height compensation: 2x 20 mm (0.8 in.), 2 x 10 mm (0.4 in.) and 4x 5 mm (0.2 in.), and two black cardboard sheets (each one A4/letter size) so that the print on the back side cannot shine through the paper.

Dimensions (WxHxD): 465 x 130 x 450 mm (18.3 x 5.1 x 17.7 in.)

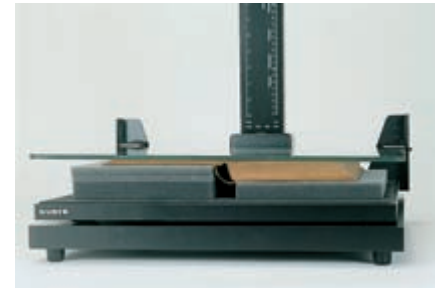
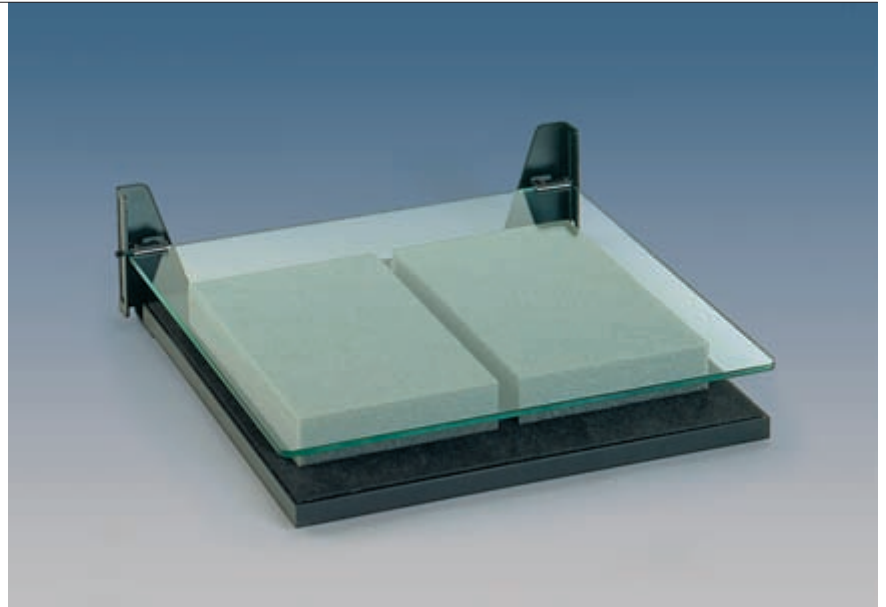

## 5539 RLR Camera Arm

For Copylizer and R1 system camera stands. For page-by-page copying from opened books or albums without moving the original. Camera platform can be shifted to left or right and locked in any position. Adjustable end-stops. Camera can be mounted in landscape or portrait position.

Moving distance of camera platform: 15 cm (5.9 in.) from center to right or left.

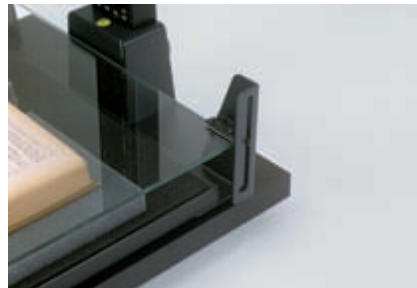



### 5631 Book Cradle 45/30

Special support for copy work from books with open sizes up to 60 x 45 cm (23.6 x 17.7 in.) and a thickness of 15 cm (5.9 in.). Lockable pressure plate made of 6 mm thick float glass, with antireflection coating on both sides. Easy to unlock by means of release rails on both sides. Glass plate locates in opening position. Two foam-padded platforms – each 30 x 45 cm (11.8 x 17.7 in.) – with adjustable space for spines of different sizes. One-time height adjustment for optimal pressure by means of spindle drive with hand crank. Subsequently automatic pressure control after each turning of a page. Mechanism for quick pressure release and subsequent resetting with previous pressure. Fold-out support bracket to hold large-sized books (up to 90 x 60 cm / 35.4 x 23.6 in. open size) while individual pages are positioned underneath the pressure plate.

Dimensions (WxHxD): 860 x 555 x 650 mm  
(33.9 x 21.9 x 25.6 in.)

Weight: approx. 57 kg (125.6 lbs.)



### 5630 Table

For Book Cradle 5631. Sturdy steel tube construction with four casters (two are lockable) and matt-grey, plastic-laminated base board 86 x 60 x 3.2 cm (33.9 x 23.6 x 1.3 in.). Casters can be exchanged with height-adjustable feet (incl.).

Also suitable as a lower table for copying works together with „RSP Xtra“ Camera Stand.

Dimensions (WxD): 92 x 68 cm (36.2 x 26.8 in.)  
Height with casters: 32 cm (12.6 in.)  
Height with feet: 25 cm (9.8 in.)

## 5901 Copy Plate

Metal base plate with non-slip bottom surface. Top surface is matt grey lacquer with 18 % reflection for determining exposure times. Printed grid lines with scales and DIN format markings. Wall mounting is possible.

Size of printed grid area: 460 x 340 mm  
(18.1 x 13.4 in.)

Dimensions (WxHxD): 500 x 10 x 380 mm  
(19.7 x .4 x 15 in.)

4 copy subject holders made of permanently magnetised section plastic.

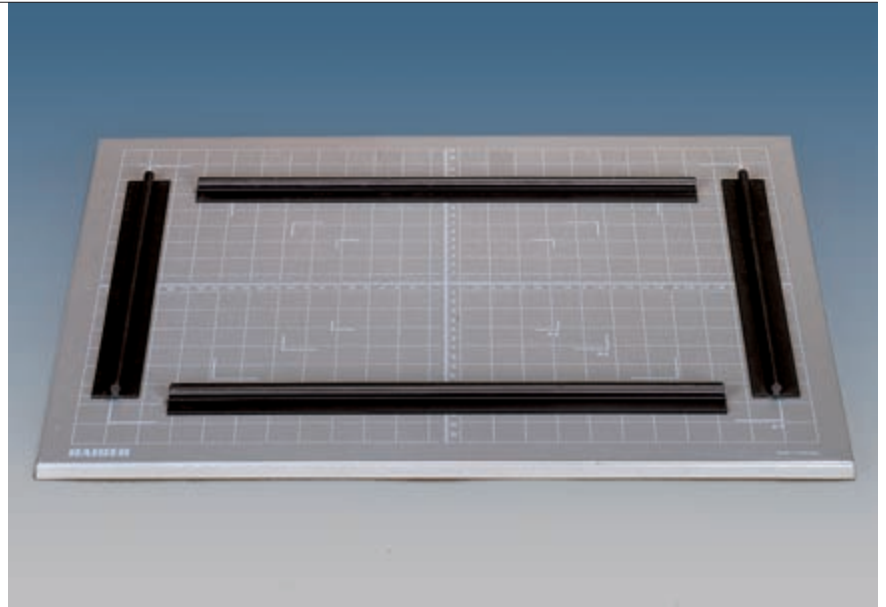

## 5903 Document Stage

Suitable for documents and originals up to 210 x 148 mm (8.2 x 5.8 in.).

Two adjustable stop rails for accurate positioning of the document. Fixing clamps can be used in various positions.

Platform on ball head can be swivelled and tilted in all directions and pivots to 90°. Height adjustment (up to 40 mm/1.5 in.) with blocking screw. Spirit levels in platform and base. Four individually adjustable feet.

Dimensions (WxHxD): 265 x 173 (213) x 210 mm (10.4 x 6.8 (8.4) x 8.3 in.)





**5907-08**  
**Reflection Shield**

Avoids reflection of the camera body on reflective originals. Attaches with holding ring in camera filter mount.

**5907:** For lenses with 62, 58 and 55 mm filter thread

**5908:** For lenses with 55, 52 and 49 mm filter thread



**6378**  
**„Action Level Cross“**  
**Digital Level**

Cross indicator with 13 LEDs for simultaneous two-dimensional indication. Additional 7 LED side level indicator. Provides level check for camera in landscape or portrait position.

See page 174 for detailed description.



**6383**  
**„Action Level Sound“**  
**Digital Spirit Level**

Can be used in portrait and landscape formats. Levelling is indicated by LEDs of different colors and/or varying beep sounds. Brightness, sensitivity and signalling can be adjusted.

See page 174 for detailed description.



**6385**  
**Spirit Level**

One level each for vertical and horizontal shooting position. With mounting shoe and 1/4" tripod bush.

Dimensions: approx. 20 x 25 x 35 mm  
(.8 x 1 x 1.4 in.)



**6386**  
**Spirit Level**

Circular bubble, self-adhesive. For permanent attachment to cameras, tripods etc. Can also be screwed on.



**6387**  
**Duplex Spirit Level**

With twin levels and two mounting feet for landscape and portrait position. Transparent housing. Attaches to the camera's accessory shoe.

Dimensions: approx. 18 x 18 x 33 mm  
(0.7 x 0.7 x 1.3 in.)