

Accessories for Digital Photography

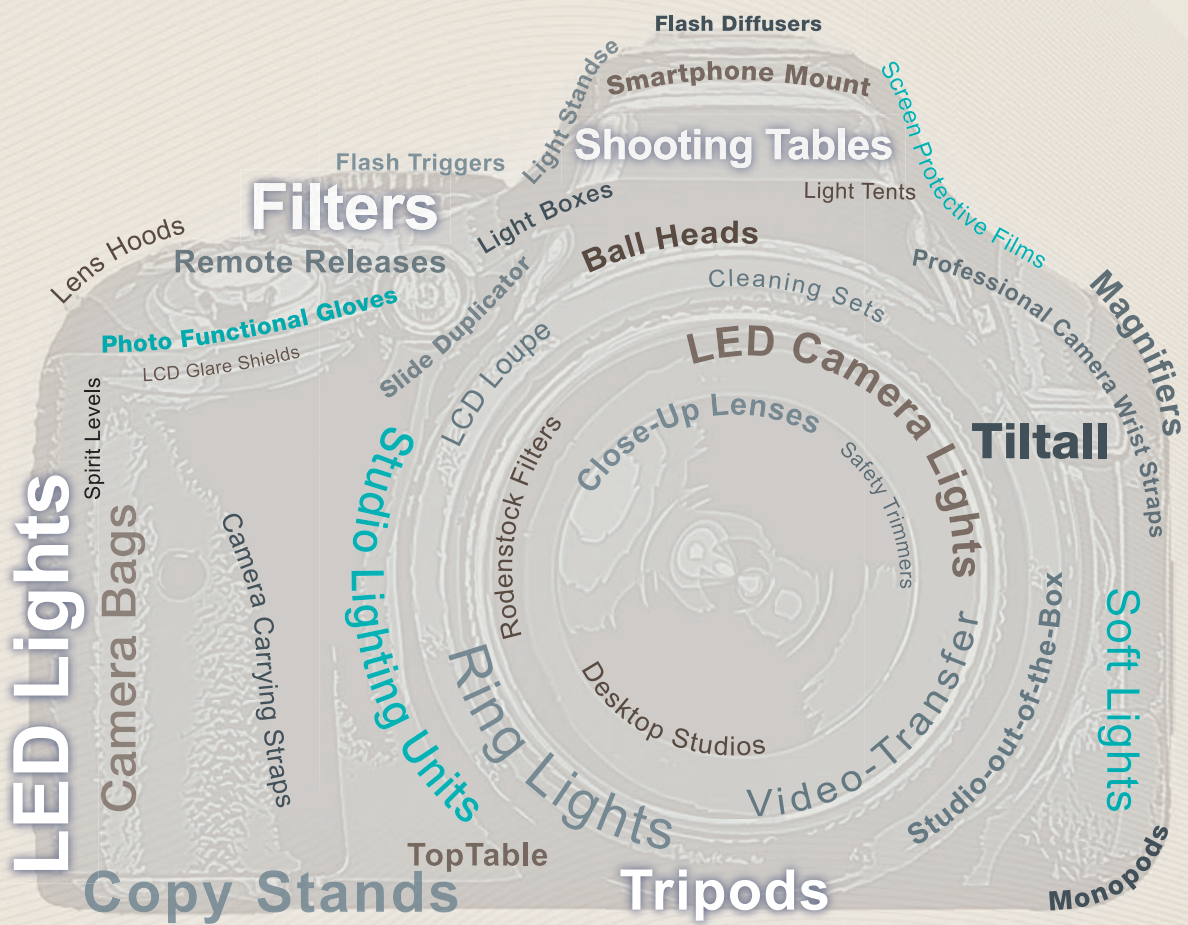

With
photokina
News

It's More Than Three Legs:

Tiltall tripods are modern tripods with a history behind them, because since 70 years there are Tiltall tripods on the market. But this is another story, that cannot be told now. Here are the facts for today's Tiltall tripods and you will see: There is more to it than three legs!

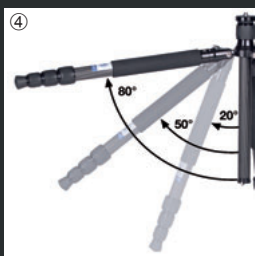

Tiltall Tripods

- Sturdy tripods. Tripod legs and column made from eight-layer carbon with little weight and very good vibration absorption (6069-6071, 7061) resp. aircraft aluminium (6066-6068, 7060).
- 180 degrees reversible legs for reduced pack size. ①
- One tripod leg is detachable and can be converted to a monopod by adding the removable center column. ②
- Reversible center column for macro shots. Center column can also be removed for close-to-ground level-setting. ③
- Four-section tripod legs with anti-twist protection and twist locks for fast and easy operation.
- Spread angle of legs can be individually adjusted and locked in three positions, covered ratchet toothing with release button. ④
- Extendable center column with anti-twist device, twist lock and spring loaded hook.
- Rubber feet with retractable metal spikes made from stainless steel.
- 1/4"-3/8" interchangeable thread.
- Tripod legs with leg warmers made of foam layers.
- Padded carrying case with adjustable shoulder strap and carry handle. ⑤



Tiltall TE-254 in combination with BH-20 Ball Head



Tiltall TE-324 Tripod



Tiltall TE-324 in combination with BH-30 Ball Head



Tiltall TE-284 Tripod



Tiltall TE-254 Tripod



Tiltall TC-224 Tripod

Code no.	6066	6067	6068	7060
Type	TE-224	TE-254	TE-284	TE-324
Material	Alu	Alu	Alu	Alu
Tube ø, max. (mm)	22	25.5	29	32.5
Max. height (cm)	137	147	162	174
Min. height (cm)	14	14	15	17
Pack size (cm)	40	43	47	50
Monopod height	67-143	71-152	78-169	83-184
Weight (kg)	1.1	1.4	1.8	2.3
Max. load (kg)	8	8	12	15
Recommended ball head	BH-10	BH-20	BH-30	BH-30
Code no.	6069	6070	6071	7061
Type	TC-224	TC-254	TC-284	TC-324
Material	Carbon	Carbon	Carbon	Carbon
Tube ø, max. (mm)	22	25.5	29	32.5
Max. height (cm)	137	147	162	174
Min. height (cm)	14	14	15	17
Pack size (cm)	40	43	47	50
Monopod height	67-143	71-152	78-169	83-184
Weight (kg)	0.9	1.1	1.4	1.9
Max. load (kg)	8	8	12	15
Recommended ball head	BH-10	BH-20	BH-30	BH-30



Tiltall

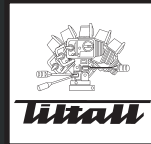

Tiltall BH-30 Ball Head



Tiltall BH-20 in combination with TE-254 tripod

Code no.	6009	6001	6002	6003
Type	BH-07	BH-10	BH-20	BH-30
Ball diameter (mm)	30	30	36	44
Height (mm)	85	85	91	100
Socket-ø (mm)	45	45	51	60
Weight (g)	310	325	395	510
Max. load (kg)	8	8	10	12
Suitable for tripods	TE-225 TC-225	TE-224 TC-224	TE-254 TC-254	TE-284 TC-284

Tiltall Ball Heads

- Solid ball head with dovetail clamping (Arca-Swiss compatible).
- Quick-release plate with non-slip surface, detachable slide-off protection and 1/4" D-ring screw.
- Three spirit levels for exact alignment.
- Adjustable friction (except BH-07).
- 360 degree panning socket with blocking screw and graduated scale.
- 3/8" tripod bush.
- Quick-release plates are also available individually.



7070

Tiltall



6007:
Length 100 mm

6006:
Length 60 mm

6005:
Length 50 mm

6004:
Length 40 mm

Tiltall Quick Release Plates

Quick release system with dovetail clamping and blocking screw (Arca-Swiss compatible). Detachable slide-off protection and 1/4" camera screw, width 39 mm, height 10 mm. Any quick release plate is suitable for all Tiltall ball heads (6001-03, 6009).

Tiltall Travel Tripods „2go“

Light-weight tripods with especially compact pack size!

- Optionally carbon or aluminium, black
- Five-section tripod legs with anti-twist protection. Spread angle of legs can be individually adjusted and locked in three positions, covered ratchet toothing. 180 degrees reversible legs. All with leg warmer. Anti-skid rubber feet.
- Movable and extendable center column, with twist locks and load hook. Reversible center column for macro shots. Tripod can also be used without center column. 1/4" / 3/8" interchangeable thread.
- One detachable tripod leg can be used as a monopod.
- Padded carrying case.

Code no.	6057	6058
Type	TE-225	TC-225
Material	Alu	Carbon
Tube ø, max. (mm)	22	22
Max. height (cm)	122	122
Min. height (cm)	12.5	12.5
Pack size (cm)	31.5	31.5
Monopod height	49-125	49-125
Weight (kg)	1.01	0.85
Max. load (kg)	7	7
Recommended ball head	BH-07	BH-07



Travel Tripod 2go (TC-225)

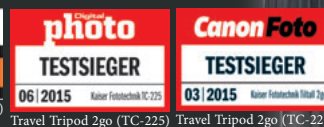

Travel Tripod 2go (TC-225)



Travel Tripod 2go (TC-225)



Travel Tripod 2go (TC-225)



Travel Tripod 2go (TE-225)



Travel Tripod 2go (TC-225)

NEW Tiltall Travel Tripod-Kit „2go“

Consisting of Tiltall Travel Tripod "2go" (6057 or 6058), BH-07 ball head (6009) plus padded carrying case. Compared to the standard versions, the tripod and ball head of this kit are titanium grey/black.

7066: TE-225 K, with TE-225 aluminium tripod
7067: TC-225 K, with TC-225 carbon tripod



Tiltall K-205 2-Way Video Head

- Pan-and-tilt head for smooth camera work. Suitable for camcorders, video cameras, DSLR cameras, spotting scopes, telescopes etc.
- Quick release adapter with safety lock. Quick release plate has interchangeable 1/4" and 3/8" screws, retractable anti-twist protection pin and a nonslip support surface.
- Quick release plate also available separately as an accessory (code no. 7071).
- 360° panning range socket with spirit level, locking screw and 3/8" tripod thread.

Length: 39.5 cm (15.6 in.)
Width: 13.5 cm (5.3 in.)
Height: 10.5 cm (4.1 in.)
Max. load: 6 kg (13.2 lbs.)
Weight: 830 g (1.8 lbs.)
Base diam.: 62 mm (2.4 in.)



Tiltall

Tiltall Handle

For the modification of a Tiltall monopod or a detached Tiltall tripod leg to a lens support or a walking stick.



6072

Tiltall Monopods

- Compact and sturdy monopods.
- Quick set-up by simultaneous opening of all twist locks.
- Sections with anti-twist protection.
- Detachable rubber foot on stainless steel spike.
- Exchangeable threads: 1/4" / 3/8".
- Foam rubber leg warmer protects against cold.
- Wrist strap.
- Carry bag included.



6061



Tiltall MP-284C Monopod

Tiltall Bi-Pod

- Compact and sturdy monopod (carbon) with tripod base for safe standing:
 - 6062: Tripod base (alu): Spread angle of legs can be individually adjusted and locked in three positions, covered ratchet toothing with automatic reset release button.
 - 6059: Tripod base (aluminium/steel) with ball head for rotating the monopod by 360° and tilting up to 18° in all directions. Each position can be locked. Centering for vertical position.
- Can be used as a conventional monopod when tripod base is detached or folded upwards (for description and specs see MP-284C monopod, code no. 6061).
- 180° degrees reversible tripod base legs for reduced pack size. Non-slip rubber feet.
- Comes with a padded carrying case with adjustable shoulder strap and carry handle.



6059



NEW

Code no.	6060	6061	6063	6064
Type	MP-284	MP-284C	MP-315	MP-315C
Material	Alu	Carbon	Alu	Carbon
Sections	4	4	5	5
Tube ø, max. (mm)	29	29	32.5	32.5
Max. height (cm)	162	162	187	187
Min. height (cm)	51	51	50	50
Pack size (cm)	51	51	50	50
Weight (g)	550	420	650	490
Max. load (kg)	11	12	14	15

6062	6059
BM-868C	BM-826C
Carbon	Carbon
4	4
29	29
189	170
59	61
54	61.5
860	860
8	8

NEW Tiltall „Escord“ Camera Bags

Camera bags of timeless stylish design, give your equipment reliable protection in all kinds of weather. Detachable and adjustable carrying strap, metal D-rings and snap hooks. All bags (except TB-03) with sturdy water-repellent bottom, captive rain cover in Velcro pocket on back side and mesh pockets on both sides.

- Escord TB-03** (820203): For compacts. With zippered front pocket for small accessories. Interior dimensions (WxHxD): approx. 7 x 11.3 x 3.8 cm (2.8 x 4.4 x 1.5 in.)
- Escord TB-05** (820205): For high-class compacts and compact mirrorless system cameras with pancake lens. Interior dimensions (WxHxD): approx. 8 x 13.5 x 7 cm (3.1 x 5.3 x 2.8 in.)
- Escord TB-41** (820241): Holster bag for mirrorless system cameras and bridge cameras. Interior dimensions (WxHxD): approx. 14 x 13 x 9 cm (5.5 x 5.1 x 3.5 in.)
- Escord TB-43** (820243): Holster bag for DSLRs and mirrorless system cameras. Interior dimensions (WxHxD): approx. 16.5 x 17 x 11 cm (6.5 x 6.7 x 4.3 in.)
- Escord TB-54** (820254): Camera bag for mirrorless system cameras, entry level DSLRs and bridge cameras. Interior dimensions (WxHxD): approx. 18 x 14.5 x 10 cm (7.1 x 5.7 x 3.9 in.)
- Escord TB-56** (820256): Camera bag for DSLRs and larger mirrorless system cameras. Interior dimensions (WxHxD): approx. 22 x 17 x 13 cm (8.7 x 6.7 x 5.1 in.)



Portable Protection

„EasyLoader“ Holster Bags

With accessory pockets inside the outer lid and on both sides. Internal lid can be connected via a Velcro closure. Spacious front pocket with organizer pouches and zipper. This camera bag allows quick access, as the top opens away from the body and stays open in a fixed position. With carrying handle and detachable, adjustable and padded shoulder strap.

EasyLoader S (8817), inside dimensions: 13 x 12 x 9.3 cm (5.1 x 4.7 x 3.7 in.)

EasyLoader (8818), inside dimensions: 15.5 x 15 x 10.5 cm (6.1 x 5.9 x 4.1 in.)



8817



8827



„SmartLoader“ Camera Bags

Lid opens away from the body and stays open in a fixed position thus providing quick access to the camera. Three mesh pockets. Zipped front pocket with overlapping cover and inside card pocket. Main compartment with divider. Padded handle. Adjustable carrying strap and shoulder pad. Belt loops.

SmartLoader S (8825): for megazoom cameras and camcorders. Inside dimensions (WxHxD): 10.6 x 13 x 8.7 cm (4.2 x 5.1 x 3.4 in.).

SmartLoader M (8826): for bridge cameras, mirrorless interchangeable-lens cameras and camcorders. Inside dimensions (WxHxD): 16 x 10 x 9 cm (6.3 x 3.9 x 3.5 in.).

SmartLoader L (8827): for DSLR cameras. With lens support divider. Inside dimensions (WxHxD): 17.5 x 13 x 10 cm (6.9 x 5.1 x 3.9 in.).

„digiShell 2“ Hard Shell Camera Bag

Compact camera bag with hard shell exterior and two-way zipper. Interior accessory pocket. With belt loop, detachable carrying strap and snap hook. Inside Dimensions (WxHxD): 11.3 x 6.7 x 3.8 cm (4.4 x 2.6 x 1.5 in.)

8287: black

8289: grey



8818

Photo Functional Gloves



Half finger gloves with mitten cover and thumb cover provide for perfect mobility, secure grip and ideal protection against cold. Mitten and thumb cover can be folded back and fastened with a Velcro strip. Made of breathable, skin-friendly fleece with anti-slip coating.

6370: Size M

6374: Size XL

6372: Size L

6376: Size XXL

Battery Box

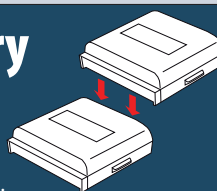

For 4 AA or AAA batteries. 2 pieces. Stackable. Color: grey and blue



6497



6494

Memory Card Box

Flat metal box for three SD / Multimedia / xD / Memory Stick cards. Dimensions: approx. 9.5 x 6 x 0.5 cm (3.7 x 2.4 x 0.2 in.)

Keep a Firm Grip!



„Action Strap“ Fast Access Strap

„Action Strap“ allows for safe carrying of your camera, but also for fast and easy access for shooting. The strap runs diagonally across breast and back, the camera rests sideways on the hip. Via a short coupling piece the camera is connected to a threefold secured locking element that moves along the strap. The camera can be placed at any desired position by stops sliding along the strap, e.g. on your back when riding a bike, on your hip during a photo tour or on your chest when skiing. The coupling piece is attached to the tripod thread of the camera without the needs of any tools and rotates freely. Both ends of the strap are connected at shoulder height by means of a quick release lock with a 120° joint. The extra-wide shoulder pad is made from 7 mm soft Neoprene with a non-slip layer. A secondary adjustable strap fits under the arm to keep the main strap in position, especially during fast moves. The total length of the strap can be adjusted between 110 and 155 cm (43 and 61 inches).

Code no. 6760

Professional Camera Wrist Straps

Suitable for larger compacts, (D)SLRs and CSCs. Soft padded genuine leather hand support with adjustable fixtures. 1 cm flat camera mounting plate with 1/4" tripod thread, countersunk fastening screw and nonslip camera support. Mounting plate of 6701 and 6702 with foldable legs providing a secure stand when put on table or floor. 6704 with Arca-Swiss compatible quick release plate, which can be fit in four directions due to its square base. 6702 and 6704 with additional safeguard wrist strap.



6701: „PRO“ Wrist Strap



6702



6704

6704: „PRO connexion 2.0“ Wrist Strap



Vintage 2-in-1 Wrist Strap

NEW

6733 For mirrorless interchangeable lens cameras or via an adapter piece for compact cameras with only one fastening eye, then detachable via a quick release fastener. Outside: Nubuck leather, inside: soft Chamude®.



Carrying Straps and Wrist Straps

For compacts with one fastening eye.

- 6735 Wrist strap, silver chain with clear plastic cover, length: 24 cm (9.4 in.).
- 6745 Neck chain, silver chain with clear plastic cover, length: 46 cm (18.1 in.).
- 6731 Wrist strap, soft elastic textile fabric, length: 25 cm. **NEW**
- 6744 Carrying strap, soft elastic textile fabric, length: 47 cm. **NEW**
- 6747 Reflective carrying strap, with quick release lock. Width 1 cm (0.4 in.), length: 47 cm (18.5 in.), silver/black.
- 6742 Neoprene camera strap. High carrying comfort, quick release lock for camera. Width: 45/30 mm (1.8/1.2 in.), length: 53 cm (20.9 in.)

Camera Shoulder Straps

For cameras with two fastening eyes. Length adjustable.

- 6743 „Neopren 2-in-1“ camera strap. For mirrorless system cameras or - with quick release fasteners attached - for compacts (e.g. Panasonic TZ). Width: 45/30 mm (1.8/1.2 in.), length: 108 cm (42.5 in.) max., 124 cm (48.8 in.) with quick release fasteners. **NEW**
- 6780 Neoprene strap. Detachable end sections, can be reconnected to serve as a wrist strap. Width 65/40 mm (2.6/1.6 in.), length: max. 140 cm (55.1 in.).
- 6791 Professional camera strap. Heavy-duty strap with non-slip protection. Width 50/12 mm (2.0/0.5 in.), length: 110 cm (43.3 in.).
- 6765/66 Woven camera strap with genuine leather applications. For mirrorless system cameras or lightweight DSLRs. Width: 25 mm (1 in.), length: max. 110 cm (43.3 in.). **NEW**

6765: Ebony 25, black 6766: Ivory 25, ivory-colored



TWIN1: Fully Released . . .

No matter if you want to use infrared, radio-controlled or wired release for your camera, you will find a suitable TWIN release. And as every release can be used wired or wireless, they are consequently called TWIN.

TWIN1 R3/R4: Infrared Wireless and Wired Remote Releases



Twin1 R4 Infrared Transmitter/Receiver Kit

Transmitter

- Applicable as an IR remote shutter release and cable release (for exceptions see survey page 8)
- Working range up to 100 m (330 ft.) with separate receiver, 50 m (165 ft.) (Nikon, Pentax, Samsung) or 25 m (82 ft.) (Canon) with cameras with built-in receiver
- Two-step release button, delay shot (wireless) and bulb shot mode
- Built-in flashlight LED
- Includes 1 m (39 in.) release cable

TWIN1 R4 Receiver (except for 6167)

Streamlined design. Two red LEDs for release control. Size: 30 x 40 x 25 mm (1.2 x 1.6 x 1 in.).

TWIN1 R4N Receiver (6167)

Extremely small and light-weight (6 g / 0.2 oz.). Red LED for release control. Powered by camera, needs no extra battery. Size: 15 x 15 x 22 mm (0.6 x 0.6 x 0.9 in.).



Twin1 R3

Transmitter only (similar to R4) for cameras which are already equipped with a built-in IR receiver. Release cable included. Working range up to 50 m (165 ft.) with Nikon, Pentax and Samsung cameras, up to 25 m (82 ft.) with Canon cameras.

See page 8 for a product overview.

TWIN1 RF: Radio-Controlled Wireless and Wired Remote Releases

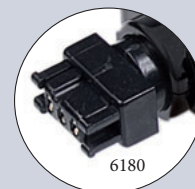

Twin1 RF transmitter

- Applicable as an RC remote shutter release and cable release
- Working range up to 100 m (330 ft.)
- Two-step release button, delay shot (wireless) and bulb shot mode
- Built-in flashlight LED
- Operation frequency: 2.4 GHz
- Size: 88 x 26 x 17 mm, 19 g (3.5 x 1 x 0.7 in, 0.7 oz.)
- Includes 1 m (39 in.) release cable

Twin1 RF receiver (except for 6179)

- Streamlined design
- Two red LEDs for release control
- Size: 30 x 40 x 25 mm (1.2 x 1.6 x 1 in.)

Twin1 RFN receiver (6179)

- Extremely small and light-weight (6 g / 0.2 oz.)
- Red LED for release control
- Powered by camera, needs no extra battery
- Size: 15 x 15 x 22 mm (0.6 x 0.6 x 0.9 in.)



See page 8 for a product overview.



Even More



6131-34

MonoCR: The Cable Release

This compact and ergonomically shaped cable release is very similar to your camera's release button. Most useful in macro photography, when using large telephoto lenses or for long exposures, a cable release ensures vibration-free shooting.

Two-step release: At the first pressure point TTL metering and auto focus is activated, the second triggers the shutter. For bulb shots the button can be locked (color indicator). The release cable can be detached and extended using the 2 m (6.6 ft.) extension cable (code no. 6185).

Length of coiled cord (extended): approx. 90 cm (35.4 in.)

Dimensions: approx. 105 x 34 x 23 mm

(4.1 x 1.3 x 0.9 in.)

Weight: approx. 30 g (1.1 oz.)

Product overview, see table below.

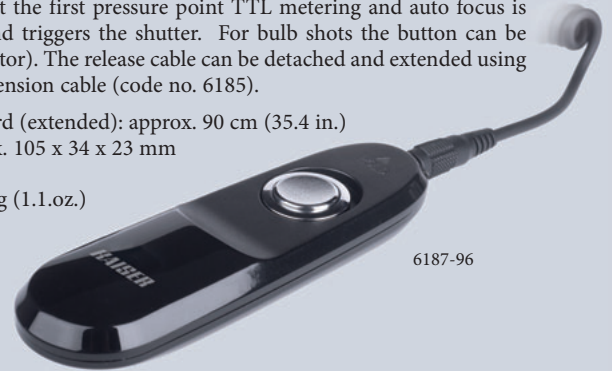

6187-96

TWIN1 ISR 2: The Multifunctional Cable Remote Release

- for interval exposure
- for timer-controlled exposure
- for long exposure
- for continuous shooting

Delayed start is supported. Timer and interval time ranges from 1 second to 99 hours, 59 minutes, 59 seconds. Exposure numbers range from 1 to 9.999. 4-way-operation button. All buttons can be locked to prevent unintentional operation. Beep sound can be switched off. Low battery warning. Normal shutter release can be used without a battery fitted, all other functions require a battery. Illuminated trible-spaced LCD. Easy user interface for all settings.

- Battery: 3V (CR 2032)
- Operating time: approx. 2 months
- Release cable length: approx. 1 m (39 in.)
- Size (w/o cable holder): 110 x 26 x 18 mm (4.3 x 1 x 0.7 in.)
- Weight: 26 g / 0.9 oz. (incl. batteries)

Product overview, see table below.

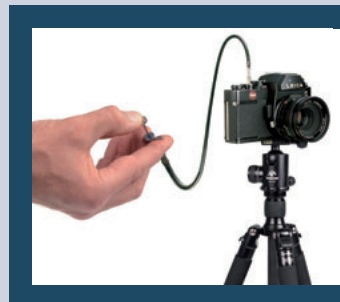

Cable Release

Threaded rotating tip.

With black plastic covering:

6109: 30 cm, locking screw

6110: 50 cm, locking screw

With black fabric coating:

6105: 50 cm, locking screw

6108: 50 cm, auto-lock disc



Product Survey

Canon: 1D C, 1D X (Mark II), 1D(s) (Mark II(N)/III), 1D Mark IV, 5D (Mark II/III/IV), 5DS (R), 6D, 7D (Mark II), 10D, 20D, 30D, 40D, 50D, D30, D60

Canon: 1000D, 1100D, 1200D, 1300D, PowerShot G1X, G3X, G5X, G10, G11, G12, G15, G16; **Fujifilm:** X-E1, X-E2(s), X-Pro2, X-T1, X-T2, X-T10, X70, X100T; **Samsung:** GX-1L, GX-1S, GX-10, GX-20, NX 5, NX 10, NX 11, NX 100, **Sigma:** SD1 Merrill, SD14, SD15

Canon: 60D, 70D, 80D, 100D, 300D, 350D, 400D, 450D, 500D, 550D, 600D, 650D, 700D, 750D, 760D; **Pentax:** *istD, *istDL(2), *istDS(2), K-3(II), K-5, K-5 II(S), K-7, K10D, K20D, K-30, K-70, K100D, K110D, K200D, 645D, 645Z; **Samsung:** GX-1L, GX-1S, GX-10, GX-20

Canon (IR only, no accessory terminal): EOS M, **Pentax** (IR only, no accessory terminal): K-m, K-r, K-S1, K-x, X5

Fujifilm: S1, X-A1, X-A2, X-A3, X-E2(s), X-M1, X-Pro2, X-T1, X-T2, X-T10, XQ1, XQ2, X30, X70, X100T

Nikon: D1, D1H, D1X, D2, D2H(s), D2X(s), D3(s), D3(x), D4, D4S, D200, D300(s), D700, D800(E), D810; **Fujifilm:** S3pro, S5pro

Nikon: D90, D600, D610, D750, D3200, D3300, D5000, D5100, D5200, D5300, D5500, D7000, D7100, D7200, Coolpix A, P7700, P7800

Nikon (IR only, no accessory terminal): D40(x), D50, D60, D70(s), D80, D3000, D3400, 1 J1, 1 J2, 1 J3, 1 V1, 1 V2, 1 V3, Coolpix P7100

Nikon: Df, D3100

Olympus: E-30, E-410, E-420, E-510, E-520, E-600, E-620, PEN: E-P1, E-P2, E-P3, E-P5, E-PL2, E-PL3, E-PL5, E-PL6, E-PL7, E-PM1, E-PM2, E, OM-D E-M1, OM-D E-M5 (Mark II), OM-D E-M10 (Mark II), SH-1, SP-100EE, SP-510UZ, SP-550UZ, SP-560UZ, SP-565UZ, SP-570UZ, SP-590UZ, SP-810UZ, SZ-11, SZ-20, SZ-30MR, XZ-1, XZ-2

Panasonic: FZ20, FZ30, FZ50, FZ100, FZ150, FZ200, FZ300, FZ1000, G1, G2, G3, G5, G6, G10, G70, GF1, GH1, GH2, GH3, GH4, GM1, GX1, GX7, GX8, L1, L10, LC1, **Leica:** Digilux 3, V-Lux (Typ 114), V-Lux 1, V-Lux 2, V-Lux 3, V-Lux 4

Samsung: EX2F, Galaxy NX, NX mini, NX1, NX20, NX30, NX210, NX300(M), NX1000, NX1100, NX2000, NX2020, NX2030

Sony: Alpha 33, 35, 37, 55, 57, 65, 77(II), 99, 100, 200, 300, 350, 450, 500, 550, 580, 700, 850, 900, **Minolta:** 5D, 7D

Sony: Alpha 7(II), 7R(II), 7S(II), 58, 68, 3000, 5000, 5100, 6000, 6300, HX50V, HX60(V), HX300, HX400(V), HX600, NEX-3N, RX10(II), RX100(II/III/IV), RX1RII

	Twin1 R3 System	Twin1 R4 System	Twin1 RF System	Twin1 ISR2 System	MonoCR System	MultiTrig System
Canon: 1D C, 1D X (Mark II), 1D(s) (Mark II(N)/III), 1D Mark IV, 5D (Mark II/III/IV), 5DS (R), 6D, 7D (Mark II), 10D, 20D, 30D, 40D, 50D, D30, D60		6169	6178	6131	6188	7001
Canon: 1000D, 1100D, 1200D, 1300D, PowerShot G1X, G3X, G5X, G10, G11, G12, G15, G16; Fujifilm: X-E1, X-E2(s), X-Pro2, X-T1, X-T2, X-T10, X70, X100T; Samsung: GX-1L, GX-1S, GX-10, GX-20, NX 5, NX 10, NX 11, NX 100, Sigma: SD1 Merrill, SD14, SD15		6168	6177	6131	6187	7001
Canon: 60D, 70D, 80D, 100D, 300D, 350D, 400D, 450D, 500D, 550D, 600D, 650D, 700D, 750D, 760D; Pentax: *istD, *istDL(2), *istDS(2), K-3(II), K-5, K-5 II(S), K-7, K10D, K20D, K-30, K-70, K100D, K110D, K200D, 645D, 645Z; Samsung: GX-1L, GX-1S, GX-10, GX-20	6161	6168	6177	6131	6187	7001
Canon (IR only, no accessory terminal): EOS M, Pentax (IR only, no accessory terminal): K-m, K-r, K-S1, K-x, X5	6161					
Fujifilm: S1, X-A1, X-A2, X-A3, X-E2(s), X-M1, X-Pro2, X-T1, X-T2, X-T10, XQ1, XQ2, X30, X70, X100T					6195	7001 plus 7012
Nikon: D1, D1H, D1X, D2, D2H(s), D2X(s), D3(s), D3(x), D4, D4S, D200, D300(s), D700, D800(E), D810; Fujifilm: S3pro, S5pro		6167	6179	6133	6189	7001
Nikon: D90, D600, D610, D750, D3200, D3300, D5000, D5100, D5200, D5300, D5500, D7000, D7100, D7200, Coolpix A, P7700, P7800	6162			6133	6190	7001
Nikon (IR only, no accessory terminal): D40(x), D50, D60, D70(s), D80, D3000, D3400, 1 J1, 1 J2, 1 J3, 1 V1, 1 V2, 1 V3, Coolpix P7100	6162					
Nikon: Df, D3100				6133	6190	7001
Olympus: E-30, E-410, E-420, E-510, E-520, E-600, E-620, PEN: E-P1, E-P2, E-P3, E-P5, E-PL2, E-PL3, E-PL5, E-PL6, E-PL7, E-PM1, E-PM2, E, OM-D E-M1, OM-D E-M5 (Mark II), OM-D E-M10 (Mark II), SH-1, SP-100EE, SP-510UZ, SP-550UZ, SP-560UZ, SP-565UZ, SP-570UZ, SP-590UZ, SP-810UZ, SZ-11, SZ-20, SZ-30MR, XZ-1, XZ-2					6193	7001 plus 7010
Panasonic: FZ20, FZ30, FZ50, FZ100, FZ150, FZ200, FZ300, FZ1000, G1, G2, G3, G5, G6, G10, G70, GF1, GH1, GH2, GH3, GH4, GM1, GX1, GX7, GX8, L1, L10, LC1, Leica: Digilux 3, V-Lux (Typ 114), V-Lux 1, V-Lux 2, V-Lux 3, V-Lux 4		6171	6181		6192	7001 plus 7009
Samsung: EX2F, Galaxy NX, NX mini, NX1, NX20, NX30, NX210, NX300(M), NX1000, NX1100, NX2000, NX2020, NX2030					6194	
Sony: Alpha 33, 35, 37, 55, 57, 65, 77(II), 99, 100, 200, 300, 350, 450, 500, 550, 580, 700, 850, 900, Minolta: 5D, 7D		6170	6180	6134	6191	7001 plus 7008
Sony: Alpha 7(II), 7R(II), 7S(II), 58, 68, 3000, 5000, 5100, 6000, 6300, HX50V, HX60(V), HX300, HX400(V), HX600, NEX-3N, RX10(II), RX100(II/III/IV), RX1RII					6196	7001 plus 7011

to Release!

MultiTrig AS 5.1: Rather Triggery



MultiTrig is a combined camera and flash release in one unit. And if you think you have to tell it what to release, you can forget about it. It knows already and automatically chooses the respective function. Hey, that's triggery, isn't it? In addition the transmitter has an extra flash shoe, receiving all TTL information from the camera, provided it is mounted to your camera's flash shoe.



Now here are the details:

5 Functions in 1 Unit:

1. Wired shutter release
2. Wireless shutter release
3. Wireless studio or camera system flash release
4. Auto Sensing: Automatic switching over from shutter release to flash release
5. TTL Pass-Through: Transmitter has TTL signal pass through for Canon or Nikon TTL flashguns attached to transmitter and transmitter mounted on camera



Product Survey

- 7001: MultiTrig AS 5.1 radio trigger set: Transmitter, receiver, 2.5 mm to 3.5 mm flash sync cable, 3.5 mm to 6.35 mm plug adapter and shutter release cords 1C, 3C, 1N, 3N.
- 7002: MultiTrig AS 5.1R: additional receiver for MultiTrig AS 5.1 Radio Trigger Set, incl. 2.5 mm to 3.5 mm flash sync cable and 3.5 mm to 6.35 mm plug adapter.

Shutter Release Cords

- 7004: 1C Shutter Release Cord (already included in set code no. 7001) for Canon, Pentax, Samsung, Sigma and Fujifilm cameras with 2.5 mm remote port.
- 7005: 3C Shutter Release Cord (already included in set code no. 7001) for Canon cameras with N3 port.
- 7006: 1N Shutter Release Cord (already included in set code no. 7001) for Nikon and Fujifilm cameras with 10 pin port.
- 7007: 3N Shutter Release Cord (already included in set code no. 7001) for Nikon cameras from D90 to D7200.
- 7008: 1S Shutter Release Cord for Sony and Minolta cameras with 3 pin port.
- 7009: 1P Shutter Release Cord for Panasonic and Leica cameras with 2.5 mm remote port.
- 7010: 3L Shutter Release Cord for Olympus PEN, OM-D, E-series (partially).
- 7011: 2S Shutter Release Cord for Sony multi interface port.
- 7012: 1F Shutter Release Cord for Fujifilm cameras, X-series (partially).

See page 8 for a product overview.

- Up to 120 m working distance. 7 channels can be selected, indicated by LEDs.
- 2.4 GHz radio frequency.
- Sync speed up to 1/320 second.
- Supports single and continuous shooting and bulb shot mode.
- Shutter release cords for many (D)SLRs and mirrorless compacts from Canon, Fujifilm, Nikon, Pentax, Samsung and Sigma included (cords for Sony, Minolta, Panasonic, Leica, Olympus and Fujifilm separately available).
- Batteries: transmitter 2 x AAA, receiver 2 x AAA (not included).



More Triggery Flash Releases

FlashTrig 16 The Radio Controlled Studio Flash Trigger

Compatible with many (D)SLRs and mirrorless CSCs. Transmitter with standard hot shoe mount and center contact and additional sync port socket. Low power consumption, long operating time. Flash test function. Battery operation.

- Up to 30 m (100 ft.) working distance
- 16 channels can be selected
- Sync speed up to 1/250 second
- 433 MHz radio frequency

Product Survey

7016: FlashTrig 16 radio trigger set:

Transmitter, receiver with 3.5 mm jack plug, 3.5 to 6.35 mm plug adapter, sync cable and 23A/12 V battery for transmitter. Receiver requires 2 AAA batteries (not included).

7017: FlashTrig 16R: additional receiver with

3.5 mm jack plug and 3.5 to 6.35 mm plug adapter. For triggering an additional studio flash in combination with FlashTrig 16 radio trigger set. Requires 2 AAA batteries (not included).



KAISER
FOTOTECHNIK

TwinLink T2Di

The Combined Radio Frequency and Infrared Flash Trigger

Complete Kit with transmitter and receiver for wireless triggering of studio flash and camera flash systems. Combined triggering via 2.4 GHz radio frequency and infrared signals using eight high performance LEDs. 32 user selectable channels. Transmitter and receiver with LCD panels that can be illuminated and external aerials. Automatic power cut-down after predetermined time and on/off switch. Transmitter can be attached using the camera's hot shoe or with an adhesive accessory shoe mount in a convenient location. Receiver with tripod thread

and mounting magnets for attachment on metal surfaces or via an adhesive metal plate supplied with the set. Receiver has a hot shoe and trigger cable terminals for PC and 2.5 mm jack-plug. Battery or mains operation (mains adapter code no. 6142 not included).

- Max. working range: Indoor: approx. 50 m (150 ft.), outdoor: approx. 200 m (600 ft.)
- Max. sync speed: 1/250 sec. (depending on camera and flash)



Product Survey

6126: T2Di TwinLink set, consisting of transmitter and receiver, incl. PC cord, 2.5-3.5 trigger cable, 3.5-6.3 adapter plug, adhesive accessory shoe base, 3 AAA batteries, 2 CR 2032 batteries, receiver fixture clip, adhesive metal plate.

6127: TwinLink T2RxDi receiver: incl. 2.5-3.5 trigger cable, 3.5-6.3 adapter plug, adhesive metal plate, 3 AAA batteries, fixture clip.



Flashy Accessories

NEW „Strobist“ Light Stand/Umbrella Kit

Accessory kit for off-camera flash shots with two shoe-mount flashes, also suitable for lighting design with two camera lights. Includes: 2 light stands, setting height 70-190 cm (27.6-74.8 in.), 2 metal swivel joints 1203, 2 combined reflected/transmitted-light umbrellas, Ø 90 cm (35.4 in.), with white inside fabric cover and removable outside black cover. Carrying case with openings on top and at the side and with inside pockets, outside dimensions: 76 x 20 x 17 cm (29.9 x 7.9 x 6.7 in.).

NEW Joint with Clamping Shoe and Umbrella Mount

Metal joint for clamp fastening of flashguns, lights and accessories with standard ISO foot on tripods and fixtures with 16 mm standard spigot or via the included adapter on 1/4" or 3/8" connecting threads. Upper section can be tilted and locked in detent stops. With umbrella mount, ø approx. 7.9 mm. Height 105 mm (4.1 in.).



1304

Flash Adapter For flash units with standard ISO foot and center contact mounted on a Sony/Minolta DSLR camera with 4-pin foot.



1503

Remote Flash Trigger For wireless lag-free firing of a second flash unit. With standard ISO foot and hot flash contact.



6040

Mounting Foot With accessory shoe for lighting units, flash guns etc. Tripod thread 1/4" for attachment on tripods. Dimensions: 94 x 63 x 11 mm



1000

Flash Bracket Light metal bracket with resilient contact surface. Length: 16.5 cm (6.5 in.).



1107

Angle Bracket Collapsible. Stable threepoint rest.



1407

PC-PC Flash Cable With male PC plug at both ends to connect flashguns. Length: 5 m (16.4 ft.)



1405

PC-PC Spiral Cord With male PC plug at both ends to connect flashguns. Length: 65 cm (25.6 in.).



1215

Accessory Shoe Adapter For cameras with Sony/Minolta flash shoe. Sony/Minolta ⇔ Standard/ISO



1300

Flash Shoe Adapter For cameras with hot flash shoe and flash equipment without hot flash shoe. With synchro flash socket.



1301

Flash Shoe Adapter For cameras without hot flash contact and flash equipment with hot flash contact. With synchro cable.



1303

Flash Adapter for connecting flash guns to receivers of RC remote releases, e.g. Kaiser MultiTrig/TwinLink, Pocket Wizard, etc.



1216

Mounting Shoe For mounting lights, flash units, etc. With 1/4" tripod thread.



1200

Bounce Flash Shoe For indirect flash illumination. Steplessly adjustable. Height: 45 mm (1.8 in.).



1322

Triple PC Flash Outlet For simultaneous use of up to three flash units with standard PC plugs.



1408/1409

Flash Cable With pull relief. 10 m (33 ft.). PC plug and jack plug ø 3.5 resp. 6.35 mm.

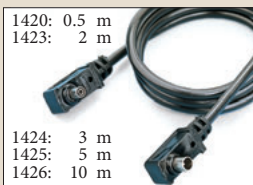

1420: 0.5 m

1423: 2 m

1424: 3 m

1425: 5 m

1426: 10 m

Extension Cord For connecting flash equipment. With right-angle plug and socket (PC).

„SoftCap“ Flash Diffuser

Slide-on diffuser made from neutral-tint, translucent plastic. To avoid hard deep shadows and reflections and to get well-balanced illumination.



- 1531 for Canon Speedlite 320EX
- 1532 for Canon Speedlite 430EX / 430EX II
- 1533 for Canon Speedlite 600EX-RT
- 1534 for Canon Speedlite 430EX III-RT
- 1540 for Nikon Speedlight SB-500
- 1541 for Nikon Speedlight SB-400
- 1542 for Nikon Speedlight SB-700
- 1543 for Nikon Speedlight SB-900 / SB-910
- 1550 for Metz mecablitz 44AF-1 / 44AF-2 / 52AF-1
- 1551 for Metz mecablitz 48 AF-1 / 50 AF-1 / 58 AF-1 / 58 AF-2
- 1552 for Metz mecablitz 64 AF-1

Vision Aids for Your Camera LCD



6074



6075

„digiShield“ LCD Glare Shield

- digiShield shields lateral and angular incidence of light from the LCD monitor and improves the visibility of the monitor image.
- digiShield folds down completely and serves also as a cover and a screen protector.
- digiShield fits almost all digital compacts and is attached to the tripod socket.
- digiShield is available for 2.7" (digiShield²) and 3.0" LCDs (digiShield³) in silver and in black.
- digiShield has coil spring supported side flaps which open automatically.
- digiShield³ flips up completely to ease the operation of touch screen LCDs.

	6074	6054	6075	6055
Screen size (diag.):*	2.7" (6.9 cm)	2.7" (6.9 cm)	3.0" (7.6 cm)	3.0" (7.6 cm)
Designation:	digiShield ²	digiShield ²	digiShield ³	digiShield ³
Colour:	silver	black	silver	black

* eventually minor border covering with 6.9 cm (2.7")



6055



6083

SV 3.2 LCD Loupe

The SV 3.2 LCD loupe suits cameras with LCDs up to 3.2" (8.1 cm) and converts the LCD into a kind of electronic viewfinder especially useful when shooting videos. If annoying light incidence makes review of focus and composition difficult or even impossible, the SV 3.2 LCD loupe will produce immediate relief. It comes with 2x magnifying lens system made of optical glass with antireflection coating, a -5 to +3 dioptre adjustment, a soft eyecup and a solid plastic housing. It attaches to the camera by means of an elastic cord and can also be mounted to fold-out monitors. The cord serves also as a neck strap. The loupe is supplied with an artificial leather bag.



NEW

Universal Loupe

Base magnifier with high-quality lens made of optical glass. Sharp, distortion-free image up to the edges. Eyesight correction from +1 to -2.5 for individual adjustment to one's own visual acuity. Light-weight, sturdy plastic housing. Translucent base for reflected and transmitted light originals.

Magnification: 4,5x
 Lens: ø 35 mm
 Viewing field: ø 45 mm (suitable for 35 mm slides)
 Height: approx. 70 mm
 Weight: approx. 56 g



2351

Pocket Microscope

30x magnification. With focussing mechanism and rotatable illumination for the viewing field. Dimensions (HxWxD): approx. 140 x 45 x 20 mm (5.5 x 1.8 x 0.9 in.)



2380

Pocket Magnifier

Flat magnifier with LED light. The LED lights up when loupe slides out. Incl. batteries.

Magnification: 3x
 Lens size: 45 x 38 mm (1.8 x 1.5 in.)



2372

Hand-Held Magnifier

Stylish magnifier with LED illumination. Ergonomically designed handle. Lens edge matt-finished and rounded off. Batteries included.

2368: Lens diameter: 65 mm (2.6 in.), magnification: 2.4x
 2369: Lens diameter: 80 mm (3.2 in.), magnification: 2.2x



Protective Shield: Screen Protectors for the Camera LCD

Anti-Reflective Screen Protective Film



High-quality film for use with digital cameras. Protects the screen from scratches, dirt and fingerprints. **Glare-free by anti-reflective layer.** Has UV protection and hard coating, optimized for touch-screens. Attaches by adhesion due to silicone coating. Easy to apply, no bubbling. Can be removed without residues. 1 piece.

6085: for 6.4 cm (2.5") screens
6086: for 6.9 cm (2.7") screens
6088: for 7.1 cm (2.8") screens
6087: for 7.6 cm (3.0") screens

6090: for 8.9 cm (3.5") screens
6092: for 10.2 cm (4.0") screens
6095: for 7.6 cm (3.0") screens
6097: for 8.9 cm (3.5") screens

Also available custom-fit for these digital SLRs and CSCs:

Canon EOS 1D C** / 1D X** (6668)
Canon EOS 5D Mark III / 5Ds(R) (6650)
Canon EOS 6D (6667)
Canon EOS 7D* (6616)
Canon EOS 7D Mark II (6676)
Canon EOS 60D (6618)
Canon EOS 70D / 80D (6676) **NEW**
Canon EOS 100D (6675)
Canon EOS 600D (6618)
Canon EOS 650D (6651)
Canon EOS 700D / 750D / 760D (6676)
Canon EOS 1100D (6619)
Canon EOS 1200D / 1300 D (6681) **NEW**
Canon EOS M (6664)
Canon EOS M3 / M10 (6675) **NEW**
Canon G1X Mark II (6675)
Canon G5X / G7X (Mark II) / G9X (6642) **NEW**
Canon G16 (6676)
Canon S120 (6618)
Fujifilm X-A1 / X-A2 / X-E2(S) / X-M1 / X30 (6682) **NEW**
Fujifilm X70 (6688) **NEW**
Fujifilm X-T1 (6683)
Fujifilm X-T10 (6677)
Leica C (6630)
Leica D-Lux 5 / 6 / Typ 109 (6631)
Leica SL (Typ 601) (6688)
Leica V-Lux (Typ 114) (6686)

Leica V-Lux 2 / 3 (6632)
Leica V-Lux 30 / 40 (6629)
Leica Q (6677)
Nikon 1 J3 / 1V 2 (6665)
Nikon 1 J4 / 1 V3 (6684)
Nikon D4 (s)** (6669)
Nikon D600* / D610* (6649)
Nikon D750* (6687)
Nikon D800* / D810* (6649)
Nikon D3200 / D3300 (6644)
Nikon D5100 / D5200 (6646)
Nikon D5300 / D5500 (6680)
Nikon D7000* (6645)
Nikon D7100* / D7200* (6670)
Nikon P510 (6629)
Olympus OM-D E-M1 / -M5 (Mark II) / -M10 (Mark II) (6642)
Olympus PEN E-P3 / -P5 (6642)
Olympus PEN E-PL7 / F (6688) **NEW**
Olympus Stylus 1(s) (6684) **NEW**
Panasonic FZ45 (6631)
Panasonic FZ48 / FZ72 (6628)
Panasonic FZ100 / FZ150 / FZ200 (6632)
Panasonic FZ300 (6688)
Panasonic FZ1000 (6686)
Panasonic G3 / G5 / GF3 / GF5 / GX1 (6628)
Panasonic G6 / GF7 / GX7 / GM1 (6677)
Panasonic G70 / GX80 (6688) **NEW**
Panasonic GF1 / GF2 (6631)
Panasonic GF6 (6642)
Panasonic GH1 / G1 / LF 1 (6630)
Panasonic GH2 / G2 (6632)
Panasonic GH3 / GH4(R) / GX8 (6642)
Panasonic LX5 / LX7 / LX100 (6631)
Panasonic TZ18 / 22 / 25 / 31 / 36 (6629)
Panasonic TZ41 (6618)
Panasonic TZ56 (6677)



UV protection



Scratch resistant



Effective adhesion



No color tint



Touch-Screen optimised



Removable, no residues



Bubble-free application

Panasonic TZ58 / TZ81 / TZ101 (6628) **NEW**
Panasonic TZ61 (6631)
Panasonic TZ71 (6630)
Pentax K-1 (6680) **NEW**
Pentax K-S1 (6676)
Pentax K-S2 (6632)
Pentax K-50/K-500 (6644)
Samsung NX30 (6642)
Samsung NX1, NX500 (6683)
Sony Alpha 7 / 7R / 7S (6641)
Sony Alpha 33 / 35 / 55 (6638)
Sony Alpha 57 / 65 / 77 (6640)
Sony Alpha 7(R) II / 7S II / 77 II (6685)
Sony Alpha 3000 / 5000 / 5100 / 6000 / 6300 (6638) **NEW**
Sony HX 50 / 60 (6629)
Sony HX 80 / HX 90 / HX 90V / WX 500 (6690) **NEW**
Sony HX 200 (6640)
Sony NEX 3 / C3 / 3N / 5 / 5N / 6 / 7 / F3 (6638)
Sony RX 1R II / 10 (II / III) / 100 (II / III / IV) (6685) **NEW**

* additional film for status LCD included

** 2 films for status LCDs included

Layer composition

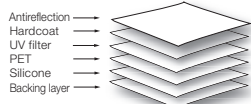

„Crystal Clear“ Screen Protective Film

High-quality clear film for use with digital cameras. Protects the screen from scratches, dirt and fingerprints. **High level of transparency, hardly visible.** Has UV protection and hard coating, optimized for touch-screens. Attaches by adhesion due to silicone coating. Easy to apply, no bubbling. Can be removed without residues.

1 piece.

6079: for 6.9 cm (2.7") screens
6080: for 7.6 cm (3.0") screens
6081: for 8.9 cm (3.5") screens
6082: for 10.2 cm (4.0") screens

6093: for 7.6 cm (3.0") screens
6094: for 8.9 cm (3.5") screens

Layer composition

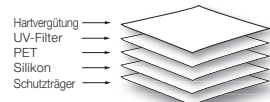

„Standard“ LCD Protective Film

For use with digital cameras and mobile phones (6076 also for GPS). Protects the screen from scratches, dirt and fingerprints. Also for touch-screens. Can be removed without residues.

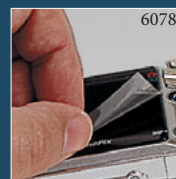

6076: Set with three 4 x 3" (10 x 8 cm) sheets each, with cutting lines for required size. Comes with cleaning cloths and a squeegee card to apply the film.

6078: For 3" LCD screens. Can be cut to fit smaller screens. Rounded corners. 3 pieces.



Lens Hoods

Designed for the lenses of digital SLRs. Fits onto the matching lens facing either forward for normal use or rearwards for storage (except 6887, mounts onto filter thread). Made of impact resistant plastic.

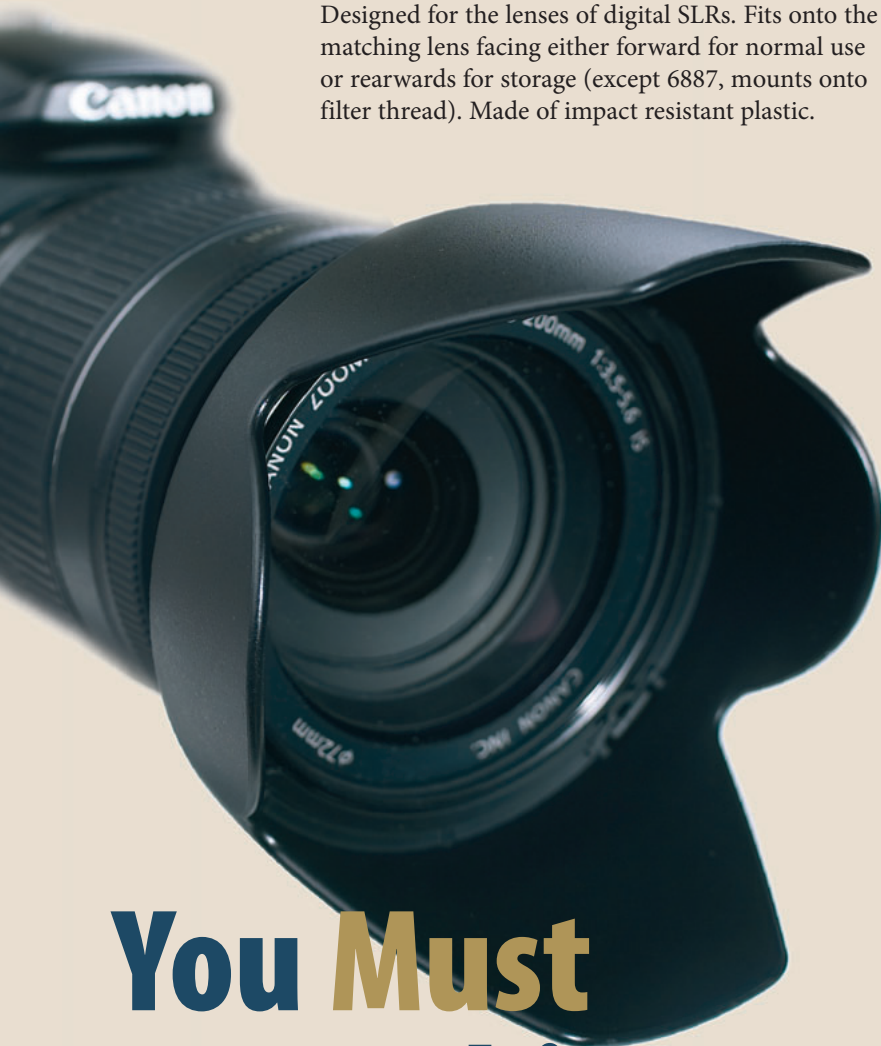

You Must Have This!

For lens	Code no.	Type
Canon EF-S 10-18/4.5-5.6 IS STM	6861	CW73C
Canon EF-S 10-22/3.5-4.5 USM	6891	CW83E
Canon EF-S 15-85/3.5-5.6 IS USM	6879	CW78E
Canon EF 16-35/2.8L USM	6891	CW83E
Canon EF 16-35/2.8L II USM	6878	CW88
Canon EF 17-40/4.0L USM	6891	CW83E
Canon EF-S 17-55/2.8 IS USM	6892	CW83J
Canon EF-S 17-85/4.0-5.6 IS USM	6889	CW73B
Canon EF-S 18-55/3.5-5.6 IS STM	6864	CW63C
Canon EF-S 18-55/3.5-5.6 IS (USM/II)	6880	CW60C
Canon EF-S 18-135/3.5-5.6 IS (STM)	6889	CW73B
Canon EF-S 18-135/3.5-5.6 IS USM	6859	CW73D
Canon EF-S 18-200/3.5-5.6 IS	6890	CW78D
Canon EF 22-55/4.0-5.6	6880	CW60C
Canon EF 24-70/2.8L USM	6874	CW83F
Canon EF 24-70/2.8L II USM	6865	CW88C
Canon EF 24-85/3.5-4.5 (USM)	6881	CW73II
Canon EF 24-105/4.0L IS USM	6876	CW83H
Canon EF 28-80 (II/USM)	6880	CW60C
Canon EF 28-90/4-5.6 II (USM)	6880	CW60C
Canon EF 28-200/3.5-5.6 (USM)	6890	CW78D
Canon EF 28-300/3.5-5.6L IS USM, white	6875	CW83G
Canon EF 50/1.4 USM	6883	CS71II
Canon EF 50/1.8 II	6887	CS62
Canon EF 50/1.8 STM	6860	CS68
Canon EF-S 55-250/4.0-5.6 IS STM	6863	CT63
Canon EF-S 55-250/4.0-5.6 IS (II)	6888	CT60III
Canon EF-S 60/2.8 Macro USM	6886	CT67B
Canon EF 70-200/2.8L IS II USM, white	6873	CT87
Canon EF 70-200/4.0L (IS) USM, white	6870	CT74
Canon EF 70-210/3.5-4.5 USM,	6884	CT65III
Canon EF 70-300/4.0-5.6 IS USM	6885	CT65B
Canon EF 70-300/4.0-5.6L IS USM, white	6869	CT73B
Canon EF 75-300/4.0-5.6 III (USM)	6888	CT60III
Canon EF 70-300/4.5-5.6 DO IS USM	6885	CT65B
Canon EF 85/1.8 (USM)	6884	CT65III
Canon EF 90-300/4.5-5.6 (USM)	6888	CT60III
Canon EF 100/2.0 USM	6884	CT65III
Canon EF 100/2.8 USM/Makro USM	6866	CT67
Canon EF 100/2.8L Makro IS USM	6868	CT73
Canon EF 100-300/4.5-5.6 (USM)	6884	CT65III
Canon EF 100-400/4.5-5.6L IS USM, white	6871	CT83C
Canon EF 135/2.8 Soft-Fokus	6884	CT65III
Nikon 1 VR 10-100/4.0-5.6	6854	NBN106
Nikon AF-P DX 18-55/3.5-5.6 G (VR)	6854	NBN106
Nikon AF-S DX 16-85/3.5-5.6 G ED VR	6898	NB39
Nikon AF-S DX 18-55/3.5-5.6G ED/EDII/VR	6894	NB45
Nikon AF-S DX 18-55/3.5-5.6G VR II	6897	NB69
Nikon AF-S DX 18-70/3.5-4.5G IF-ED	6893	NB32
Nikon AF-S DX 18-105/3.5-5.6G ED VR	6893	NB32
Nikon AF-S DX 18-135/3.5-5.6 IF-ED	6893	NB32
Nikon AF-S DX 18-140/3.5-5.6 G ED VR	6893	NB32
Nikon AF-S DX 18-300/3.5-6.3 G ED VR	6898	NB39
Nikon AF-S DX 55-200/4.5-6.6G ED VR	6895	NB37
Nikon AF-S DX 55-300/4.5-5.6G ED VR	6896	NB57
Sony DT 18-55/3.5-5.6 SAM (II)	6899	SH108

NEW

NEW

Lens Hoods for Pancake Lenses



Made of matte black rubber. Rotating connecting ring with metal mount and locking screw. Includes lens cap for use with mounted lens hood.

6829: For Panasonic 1.7/20 mm Asph (II), 2.5/14 mm Asph (II), Panasonic Leica 1.7/15 mm Asph or Olympus M. Zuiko Digital 1.8/17 mm. Also for JVC and Panasonic camcorders with 46 mm filter thread.

6831: For Olympus M.Zuiko Digital 2.8/17 mm, M.Zuiko Digital 3.5-5.6/14-42 mm II, Panasonic PZ G X 14-42 mm, also for Canon, JVC and Sony camcorders with 37 mm filter thread.

3-in-1 Lens Hoods

for lenses with 28 to 200 mm focal length (35 mm equivalent). Made of matte black silicone, foldable. With light baffles. Metal screw-in mount. Filter thread.

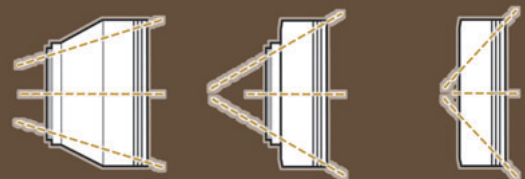

Telephoto

Standard

Wide angle

6850: ø 37 mm	6820: ø 49 mm	6824: ø 62 mm
6819: ø 40.5 mm	6821: ø 52 mm	6825: ø 67 mm
6851: ø 43 mm	6822: ø 55 mm	6826: ø 72 mm
6853: ø 46 mm	6823: ø 58 mm	6827: ø 77 mm

Even More for Your Lens: Filters

KAISER

The Kaiser filters and close-up lenses are equipped with a light alloy mount with front thread.

Kaiser UV-Filters (101 . .)

Colourless filter. Blocks UV rays, so reduces haze, avoids blurring and improves contrast. Can be used as a permanent lens protector. Slim line



metal mount, blackened at the lens edge to prevent glare effects. Double-sided coating. Supplied with storage box.

Kaiser UV-Filters MC (102 . .)

Same as Kaiser UV filters (101..) but with six-layer multi-coating on both sides and water repellent lotus effect.

Kaiser Polarizing Filters, circular MC

Induces fuller colour rendition, improves contrast and reduces or eliminates reflections on non-metallic surfaces (e.g. glass, water, car finish). Slim line metal mount, matt blackened at the lens edge to prevent glare effects. Six layer multi-coating on both sides. Rotary mount. Supplied with storage box.

Kaiser Grey Filter ND 3.0 / 1000x

Neutral density filter. Neutral colour filter for reducing high brightness, extending exposure time and intentionally reducing the depth of field. Filter factor 1000x (10 f-stops). Micro fibre cloth and pouch included.

Kaiser Vario Grey Filters ND2x – ND400x

Neutral colour filter for variably reducing high brightness, extending exposure time and intentionally reducing the depth of field. Exposure factor 2 to 400. Rotating the front ring reduces incidental light by 2 to 8 aperture increments. No vignetting with lenses of approx. 28 mm focal length and higher referred to full-frame. Comes with a lens cap, micro fibre cleaning cloth and pouch.



Close-Up Lens Set

Comprises Close-Up Lens 1 (+1 diopter), Close-Up Lens 2 (+2 diopters) and Close-Up Lens 4 (+4 diopters). Incl. case. To reduce the shooting distance and enlarge the frame. A combination of several close-up lenses is possible.



	ø 37	ø 40.5	ø 43	ø 46	ø 49	ø 52	ø 55	ø 58	ø 62	ø 67	ø 72	ø 77	ø 82
UV Filters (101 . .)	•	•	•	•	•	•	•	•	•	•	•	•	•
UV Filters MC (102 . .)	•	•	•	•	•	•	•	•	•	•	•	•	•
Polarizing Filters, circular MC (157 . .)	•	•	•	•	•	•	•	•	•	•	•	•	•
Close-Up Lens Sets (145 . .)	-	-	-	-	-	•	•	•	•	•	•	•	-
NEW Grey Filters ND 3.0 / 1000x (155 . .)	-	-	-	-	• ¹	•	• ²	•	• ³	•	• ⁴	•	-
Vario Grey Filters ND (154 . .)	•	•	-	•	• ⁵	•	•	• ⁶	•	• ³	•	• ⁴	-

• = with adapter ring ¹ incl. adapter ring ø 49 mm ² incl. adapter ring ø 55 mm ³ incl. adapter ring ø 62 mm ⁴ incl. adapter ring ø 72 mm ⁵ incl. adapter rings ø 40.5 and 46 mm ⁶ incl. adapter rings ø 52 und 55 mm

R RODENSTOCK

Rodenstock „HR Digital super MC“ and „Digital pro MC“ Filters

Both these Rodenstock filter series are made from tempered glass with highest possible surface quality and are also highly scratch-resistant. Their flat slimline mounts prevent vignetting with wide-angle lenses. The front thread (not with ø 86 and 95 mm polarizing filters) allows the use of a lens hood or of the lens cap with the filter in place. The filter mount of the less expensive Digital pro MC series is made from tempered, black anodized aluminum and is quite lightweight. The filter mount of the HR Digital super MC series is made from robust brass for optimum smooth movement of the threads. An additional water and oil repellent coating provide for the so-called lotus effect.

Rodenstock UV Filters

Steep Rodenstock UV blocking filters block out the UV radiation exactly at the border to visible

light. This is extremely efficient and they are perfectly color neutral. Due to the perfect color neutrality Rodenstock UV blocking filters are also ideal protective filters that can be left on the lens at all times.

Rodenstock Circular Polarizing Filters

Circular Polarizers reduce or eliminate reflections on surfaces, reduce the diffuse blue cast in landscape photographs and produce an improved color saturation.

Rodenstock Neutral Density Filters ND 4x, 8x

They allow the extension of exposure times by a factor of 4 or 8 for impressive smear effects or a further opening of the aperture for a considerably reduced depth of field.

Rodenstock Variable Neutral Density Filters

If more than the fixed 4x and 8x ND levels or a finer graduation is required, the Digital Vario ND EXTENDED variable neutral density filter is the right solution.



	ø 34	ø 37	ø 39	ø 40.5	ø 43	ø 46	ø 49	ø 52	ø 55	ø 58	ø 62	ø 67	ø 72	ø 77	ø 82	ø 86	ø 95
„Digital pro UV MC“ UV Filters (177 . .)	•	•	-	•	•	•	•	•	•	•	•	•	•	•	•	-	-
NEW „HR Digital UV super MC“ UV Filters (191 . .)	-	•	•	•	•	•	•	•	•	•	•	•	•	•	•	•	•
„Digital pro CPL MC, circular“ Pol. Fil.(178 . .)	-	-	-	-	-	-	•	•	•	•	•	•	•	•	•	-	-
NEW „HR Digital CPL super MC, circular“ Pol. Fil. (192 . .)	-	-	-	-	-	-	•	•	•	•	•	•	•	•	•	•	•
„HR Digital ND 0.6/4x MC“ Grey Filters (184 . .)	-	-	-	-	-	-	•	•	•	•	•	•	•	•	•	-	-
„HR Digital ND 0.9/8x MC“ Grey Filters (188 . .)	-	-	-	-	-	-	•	•	•	•	•	•	•	•	•	-	-
„Digital Vario NDEXTENDED“ Grey Filters (196 . .)	-	-	-	-	-	-	•	•	•	•	•	•	•	•	•	-	-

* MADE IN GERMANY

You Should Have This!

ProDisk



Combination of white balance, grey card and colour reference in a slim, foldable plastic housing. Colour card and grey card located in lower and upper covers. Translucent white balance filter with special surface pattern in centre. Includes neck strap.

- 6601: ProDisk mini, for lenses up to \varnothing 6 cm (2.4 in.).
Dimensions (folded down): 103 x 73 x 10 mm
(4.1 x 2.9 x 0.4 in.), weight: 75 g (2.6 oz.)
6602: ProDisk II, for lenses up to \varnothing 9 cm (3.5 in.).
Dimensions (folded down): 145 x 101 x 11 mm
(5.7 x 4.0 x 0.4 in.), weight: 135 g (4.8 oz.)



„Vivicap“ White Balance Filters



Snap-on filter with specially designed prism structured surface for white-balancing of digital cameras and camcorders. Easy to use clamping mechanism provides for quick installation and removal. Serves also as a lens cap and can also be attached when a lens hood is used.

- 6605: \varnothing 52 mm 6608: \varnothing 62 mm 6610: \varnothing 72 mm
6606: \varnothing 55 mm 6609: \varnothing 67 mm 6611: \varnothing 77 mm
6607: \varnothing 58 mm

Quick-Release Connector



For quick mounting of camera on tripod. Release lever with additional safety lock, three spirit levels for precise positioning, 3/8" tripod thread with 1/4" thread adapter.

- 6026: Quick-Release Connector, incl. Quick-Release Plate
6028: Quick-Release Plate with 1/4" threaded pin and immersible anti-twist device for camcorders/video cameras. Suitable for Quick-Release Connector 6026.

„Snap-On“ Lens Caps



Reliable hold by clamp-on design. Includes loss protection. Can also be used with lens hood mounted.

- 6845: \varnothing 37 mm 6834: \varnothing 52 mm 6839: \varnothing 72 mm
6846: \varnothing 40.5 mm 6835: \varnothing 55 mm 6840: \varnothing 77 mm
6847: \varnothing 43 mm 6836: \varnothing 58 mm 6841: \varnothing 82 mm
6848: \varnothing 46 mm 6837: \varnothing 62 mm 6842: \varnothing 86 mm
6833: \varnothing 49 mm 6838: \varnothing 67 mm 6843: \varnothing 95 mm



Style „Snap-On“ Lens Caps



High-quality and durable synthetic resin coating. Reliable hold by clamp-on design. Includes loss protection. Can also be used with lens hood mounted.

	Aperture	Iris	Nuclear	I Love Pixel	Smile Now	Union Jack	Snippets
\varnothing 49	7860	7880	7900	7920	7940	7960	7980
\varnothing 52	7861	7881	7901	7921	7941	7961	7981
\varnothing 55	7862	7882	7902	7922	7942	7962	7982
\varnothing 58	7863	7883	7903	7923	7943	7963	7983
\varnothing 62	7864	7884	7904	7924	7944	7964	7984
\varnothing 67	7865	7885	7905	7925	7945	7965	7985
\varnothing 72	7866	7886	7906	7926	7946	7966	7986
\varnothing 77	7867	7887	7907	7927	7947	7967	7987

„Digital“ Slide Duplicator

Suitable for digital cameras with filter thread. Connecting thread 52 mm. With detachable achromatic macro lens. Full size copy can be obtained using it with a lens with focal length of 80-120 mm (based on full-frame sensor), details with higher focal length. Includes holder for two slides and 58-52 mm adapter ring.



Film Strip Carrier

For six 35mm negatives or unmounted slides. For use with slide duplicator 6506.

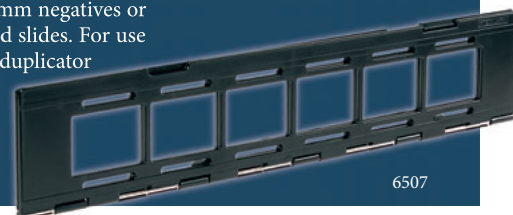

Video Transfer Unit

For copying cinefilms (8 mm, 16 mm) and slides on to video. Fine-grained viewing screen. Built-in reversing mirror for true-sided image. Strong table base with step-less height adjustment.



Camera Body Caps

Lens Rear Caps

Camera Body Caps	for	Lens Rear Caps
6521	Canon EOS	6531
6522	Minolta MD	6532
6523	Sony A-Mount / Minolta AF	6533
6525	Nikon	6535
6526	Olympus OM (analog)	6536
6527	Pentax K bayonet	6537
6528	Micro Four Thirds (Olympus/Panasonic)	6538
6529	Sony E-Mount (Nex/Alpha)	6539



Small – But Going Strong

Table top tripods are extremely compact, but provide a firm support.



DSLR Table Top Tripod

With three-section telescopic legs and extendable center column. 3-way pan head with tiltable camera platform. Height: 18-30 cm (7.1-11.8 in.), max load: 2 kg / (4.4 lbs.)



„Multi-Level“ Table Top Tripod

Height continuously adjustable, three-section telescopic feet, folds-down to compact size. Ball head with locking screw (6043) or with pan and tilt head (6052).

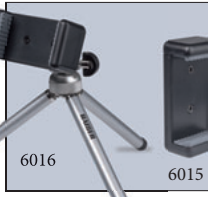

Smartphone Mount

with three 1/4" tripod threads and rubberized quick clamp for universal applications. Clamp width 55-85 mm.

Smartphone Stand (6016), comprising 6043 and 6015.



„SwingGrip“ Combined Mini Tripod and Hand Grip

NEW

Table tripod with tilt head, height 11.5 cm (4.5 in.). Can also be used as an ergonomic hand grip.

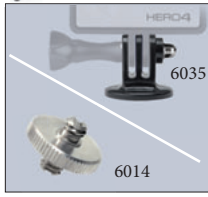

Tripod Adapter

for GoPro®/Action Cams. With 1/4" tripod thread.

Threading Adapter

with 2 x 1/4" threaded pin and lock nut.



„easy“ Camera Shoulder Pod

Combined shoulder pod and chest pod for cameras and camcorders. Pivoting mounting plate with 1/4" thread, securing pin and non-slip face. Length steplessly adjustable and lockable in any position. With adjustable strap.

6016 with 6014 and 3286 LED camera light



6045

High-Level Meeting:



Triplex Spirit Level

With three levels. Two-level horizontal alignment for landscape and portrait shots without repositioning the spirit level. Attaches to the camera's accessory shoe.



Duplex Spirit Level

With twin levels and mounting feet for landscape and portrait position. Attaches to the camera's accessory shoe.

Pixel-Perfect Cut?

This is not required. But it would be nice to have all the things „produced“ on your printer with a neat and precise cut. This makes a trimmer a PC peripheral – it is very useful anyway.

„easy cut“ Safety Trimmer

Easy and safe cutting with ground circular blade. Automatic paper clamping at cutting position. Sturdy metal base board with scales, format and angle markings.

4306: easy cut 1, cutting length: 32 cm (12.6 in.), cutting thickness: 1 mm (0.04 in.)

4307: easy cut 2, cutting length: 45 cm (17.7 in.), cutting thickness: 0.8 mm (0.03 in.)

„hobby cut“ Safety Trimmer

Self-sharpening circular blade in closed plastic housing. Automatic paper clamping at cutting position. Transparent paper-holding strip. Two angle stops with cm and inch scales. Sturdy metal base board with printed fine grid, scales, format and angle markings.

4313: hobby cut 3, cutting length: 33 cm (13.0 in.), cutting thickness: 1 mm (0.04 in.)

4314: hobby cut 4, cutting length: 46 cm (18.1 in.), cutting thickness: 1 mm (0.04 in.)

„multi cut“ Guillotine-type Trimmer

Safety trimmer with honed top and bottom blades. Manual pressing rail. Angle guide on both sides for right-angled cutting, with cm and inch scales. Detachable magnetic back stop.

4303: multi cut 3, cutting length: 34 cm (13.4 in.), cutting thickness: 1.5 mm (0.06 in.)

4305: multi cut 4, cutting length: 46 cm (18.1 in.), cutting thickness: 1.5 mm (0.06 in.)

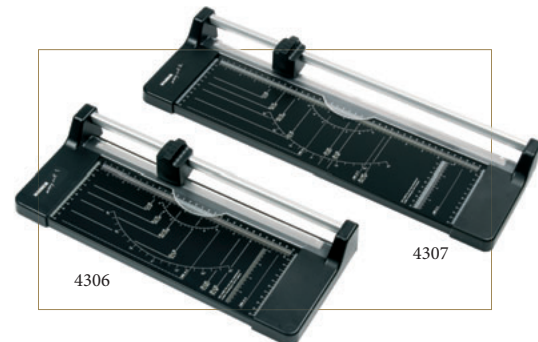

Light – Compactly Sized

Video needs light – permanently – that is continuous light. Nowadays digital cameras can shoot videos. Small add-on lights, portable and battery-powered, provide adequate illumination in a close-up range when lighting conditions are bad. StarCluster and Co. use up-to-date LED technology, provide energy-saving operation with long-life light sources and can be mounted on all camcorders and movie-making digital cameras with standard accessory shoe.

Kaiser StarCluster

This compact soft light works for both, stills and video filming and is perfect for use with D-SLRs and CSCs. It features 96 continuously dimmable white LEDs on a panel of 8.5 x 6 cm (3.3 x 2.4 in.) and provides approx. 600 lux of illumination at one meter (3.3 ft.) and 60° angle of radiation (half-value angle). The colour temperature of 5600 Kelvin relates to daylight. Electronically stabilized light output keeping the illuminance constant when supply voltage goes down. Automatic shutdown when batteries are exhausted to prevent deep discharge and battery defects. It is powered by five AA batteries fitted in the rear battery compartment or by a Canon LP-E6(N) battery, that can be placed in an adapter on the battery cover. The LP-E6(N) is the standard battery for Canon's 5D Mark II/III/IV, 6D, 7D (Mark II), 60D and 70D. There is also a connector for a mains adaptor (optional). Several lights can be combined side by side or on top of each other using a clever catching system. The light comes with a diffusion screen and an artificial light filter (3200 Kelvin) which attach to the front of the light by magnetic attachments. The package also contains a swivel joint for mounting to a standard hot shoe and a protective bag.



3270

Specifications:

Operating time with fully charged batteries: approx. 2.5 hours at full power
 Colour temperature: 5600 Kelvin
 Dimensions: 127 x 77 x 45 mm (5 x 3 x 1.8 in.)
 Weight: 195 g / 6.9 oz. (without batteries)
 Tripod thread: 1/4"
 Accessories: 3271 mains adapter



3280

Specifications:

Illumination at 1 m (3.3 ft.): max. 1150 lux
 Angle of radiation (half-value angle): 50°
 Color rendition index: CRI = 85-90
 Color temperature: 3200 - 5600 K
 Operating time with 6 NiMH batteries:
 approx. 2.5 hours at full power
 Dimensions: 152 x 110 x 49 mm (6 x 4.3 x 1.9 in.)
 Weight: approx. 280 g (9.9 oz.) (w/o batteries)

Kaiser StarCluster „144 Vario“

Powerful and dimmable LED camera light with continuously adjustable color temperature. 13 x 8 cm (5.1 x 3.1 in.) panel with 144 High-CRI-LEDs. Color temperature can be adjusted continuously between 3200 Kelvin (warm white/artificial light) and 5600 Kelvin (daylight) via a control dial. Another dial controls the light intensity and shuts the light off. Electronically stabilized light output keeping the illuminance constant when supply voltage goes down. Automatic shutdown when batteries are exhausted to prevent deep discharge and battery defects.

Power supply by 6 AA batteries or rechargeables or Sony battery type NP-F (e.g. 550, 570, 750, 770, 950, 970) or mains adapter (accessory, code no. 3281). Additional lights can be connected to all four sides of the light housing. Appropriate connecting adapters are included, also a diffuser screen with magnetic attachment. 1/4" tripod threads on top and bottom sides, in addition continuously adjustable swivel joint with accessory foot for mounting on camera hot shoe.



3272

Hand Grip

For lighting units, cameras, etc. With foam shell and grip shape.

Connection thread 1/4" and tripod thread 1/4".

Includes snap-hook with key ring and fixture for tripod thread.

Height: approx. 120 mm (4.7 in.)



Small but Mighty

Kaiser SmartCluster „Micro“

Very small and extremely compact LED camera light for photo and video, especially suitable for light-weight CSCs, smartphones/tablets and small camcorders. 24 SMD-LEDs provide approx. 230 lux of illumination at 1 m (3.3 ft.) and 100° angle of radiation (half-value angle) and can be dimmed down continuously to 10 % of maximum value. The light is powered by a NP 60 lithium-ion battery that can be recharged via the included USB cable using a PC, notebook, USB charger or a power bank. There is an indicator lamp for the battery charge condition. To prevent deep discharges and battery defects the light is switched off automatically when the batteries are exhausted. The light comes with a swivel joint with accessory foot and 1/4" tripod thread, a smartphone adapter for attaching the light to the headphone socket, a USB charge cable, a diffuser and an artificial light filter with magnetic holders.

Specifications:

Operating time with fully charged batteries: approx. 50 minutes at full power, up to 18 hours if dimmed down
 Color temperature: approx. 5800 K
 Operating voltage: 3.7 V
 Battery: NP 60, 1200 mAh
 Dimensions (WxHxD): 72 x 51 x 18 mm (2.8 x 2 x 0.7 in.)
 Weight (with battery): approx. 100 g (3.5 oz.)

Kaiser SmartCluster „Midi“

Compact LED camera light for photo and video, suitable for camcorders, DSLRs and CSCs. 80 SMD-LEDs provide approx. 190 lux of illumination at 1 m (3.3 ft.) and 120° angle of radiation (half-value angle) and can be dimmed down continuously to 7 % of maximum value. The light is powered by a NP 120 lithium-ion battery that can be recharged via the included USB cable using a PC, notebook, USB charger or a power bank. There is an indicator lamp for the battery charge condition. To prevent deep discharges and battery defects the light is switched off automatically when the batteries are exhausted. The light comes with a swivel joint with accessory foot and 1/4" tripod thread, a USB charge cable, a diffuser and an artificial light filter.

Specifications:

Operating time with fully charged batteries: approx. 90 minutes at full power, up to 18 hours if dimmed down
 Color temperature: approx. 5800 K
 Operating voltage: 3.7 V
 Battery: NP 120, 1800 mAh
 Dimensions (WxHxD): 115 x 71 x 21 mm (4.5 x 2.8 x 0.8 in.)
 Weight (with battery): approx. 135 g (4.8 oz.)



Accessory Brackets



3273: Light metal bracket for mounting two accessories with tripod thread on a tripod, hand grip or swivel joint. Especially suitable for attaching two „StarCluster“ LED lights. 2 relocatable 1/4" tripod screws with soft washers. Center placed 1/4" tripod bush. Length: 15.5 cm (6.1").



93296: For raised mounting of a light, microphone etc. next to the camcorder lens. Folding. With anti-twist pin for exact right-angled mounting on camcorder. Widened three-point rest on bottom side. Camera with mounted bracket stands firmly on all flat surfaces. 1/4" tripod thread.



3273

Universal Accessory Bracket

For camcorders and digital SLRs/CSCs and compacts. Allows for right side or left side mounting of accessories such as lights or microphones. The bracket can be aligned to the camera in different ways.

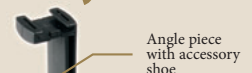

1108

Plug-in bracket with detachable anti-twist protection and tripod adapter screw

Best Circles

R 48 Ring Light

LED ring light for shadowless illumination in close-up and macro photography. Color temperature of the 48 LEDs is approx. 6000 Kelvin, illumination at 30 cm (1 ft.) approx. 1550 lux and angle of radiation 60°. Mounting on the lens is easy as the unit slides and locks on the suitable adapter ring. Six adapter rings from 49 to 67 mm are included. The light is powered by two AA rechargeable batteries (not included) housed in a separate battery compartment or by a mains adapter 3271 (optional accessory). The 24 LEDs on the left or on the right can be switched on separately.

Minimum working distance: 3 cm (1.2 in.)
 Operating time with 2 NiMH rechargeables: approx. 2.5 hours
 Colour temperature: approx. 6000 K
 Dimensions: Ring light: 11 x 13 x 3 cm (4.3 x 5.1 x 1.2 in.)
 Battery compartment: 5 x 9 x 5 cm (2 x 3.5 x 2 in.)
 Weight: Ring light: approx. 140 g (4.9 oz.)
 Battery compartment: approx. 55 g (1.9 oz.)



3248

R 60 Ring Light

Powerful LED ring light with 60 daylight LEDs (color temperature approx. 5600 K). Illumination approx. 2300 lux at 30 cm (1 ft.) and 52° angle of radiation. Light-weight and compact housing, includes battery compartments and all controls. Power supply by 4 AA batteries or rechargeables. Light can be dimmed continuously down to zero without noteworthy change of color temperature. An external power adapter (not included) can be connected. Mounts to the filter thread of the lens with aid of the appropriate adapter ring. Six adapter rings for 49/52/55/58/62/67 mm filter thread are included.

Minimum working distance: 3 cm (1.2 in.)
 Operating time: approx. 2 hours at full power, up to 30 hours if dimmed down
 Dimensions: 15 x 15 x 2.8 cm (5.9 x 5.9 x 1.1 in.)
 Weight (w/o batteries): approx. 128 g (4.5 oz.)
 Accessory: Universal power adapter with selectable output voltage (code no. 3271)



3252



KR 90 Ring Light

Professional ring light with 30 three-chip high performance LEDs. Illuminance at 30 cm (11.8 in.) approx 1850 lux. Extremely wide angle of radiation of 110° (half-value angle). A rechargeable lithium ion battery and the complete circuitry are integrated in the main body made of highly durable duralumin. Light can be dimmed down. The basic connection thread is 77 mm, several adapter rings from 52 to 72 mm are included. Light can also be mounted on a tripod. No illuminance drop-off due to battery consumption. Automatic shutdown when batteries are exhausted to prevent deep discharge and battery defects. Supply includes quick charger, car charger cable and a protective bag.

Min. working distance: 3 cm (1.2 in.)
 Operating time at full power: approx. 2 hours
 Colour temperature: approx. 5500 K
 Battery capacity: 1500 mAh
 Tripod thread: 1/4"
 Dimensions: ø 142 x 34 mm
 (ø 5.6 x 1.3 in.)
 Weight: 300 g (10.6 oz.)



3250



Keep It Clean

SpeckGRABBER™ Kinetronics
www.kinetronics.com

702002

Kinetronics' SpeckGRABBER Pro SGP (702002) removes individual particles of dust and dirt from sensitive surfaces without damaging them. Suitable for cleaning camera sensors (manufacturers instructions must be followed), SLR mirrors, lenses and oculars, films, slides, etc. With rubber-coated handle.



702001

SpeckGRABBER SG
With standard handle.



702004

SpeckGRABBER Pro Kit SGL
With integrated mini lamp, three tips, cleaning solution and anti-static cloth in robust box.



702005

SpeckGRABBER Pro Kit SGK
With SpeckGRABBER Pro handle, three tips, cleaning solution and anti-static cloth in robust box.



707001

Outdoor Photographer's Optical Cleaning Kit
Cleaning solution, anti-static cloth and brush, SpeckGRABBER SG, Swabs.



706518

700001

Anti-Static Micro-Fibre Cloth
Specially conductive fibres, 700001 for dry cleaning, 706518 for wet cleaning.



700010

700030

Anti-Static Brushes
For sensitive surfaces. 700010: width 10 mm, 700020: width 20 mm, 700030: width 30 mm



707025

„ECK“ Optical Cleaning Set
With anti-static cloth 13 x 14.5 cm and 6 ml (0.2 oz.) of cleaning solution in a drop bottle.

„Typhoon Blower“ Blower Bellows

Large rubber bulb for strong blowing effect. Rugged front air nozzle, rear air duct valve. Easy to handle. Cleaning brush included.



6316

„Mini“ Blower Bellows

Compact rubber bulb. Fine, short front air nozzle, rear air duct valve. Easy to handle. Length: approx. 10.5 cm (4.1 in.) Bellows diameter: approx. 5 cm (2 in.)



6305

„Clear Gear“ Compressed Air

For touch-free dust removal. 6308: 200 ml, propane/butane mixture, 6309: 400 ml, non-flammable fluor-ethane mixture, special high pressure version, 6310: 400 ml, propane/butane mixture



6308

6309

6310



KAISER
FOTOTECHNIK

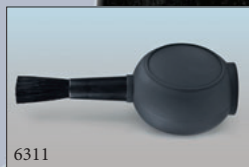

6311

Blower Brush
Round brush with silicone blower bulb. Length: 10 cm.



6314

Blower Brush
Flat brush with large rubber blower bulb.



6301

Lens Brush
In plastic tube. Lipstick twist mechanism.



6328

Micro Fibre Cleaning Cloth
Fluff-free, grease-absorbing. Hemmed edges.

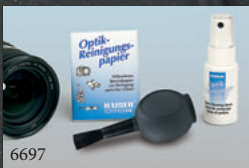

6697

Cleaning Set
Optical-glass cleaning fluid, cleaning paper and blower brush.



6699

Cleaning Set
Lens cleaning paper, cleaning leather and blower brush.



6662

Display and Optics Cleaning Kit
Pump spray and a micro fibre cleaning cloth.



6663

Cleaning Set
Cleaning pen and micro fibre cloth.

Desktop Studios



5906

Desktop studios can be set up on your desk, on your dining or living room table or wherever you like to take your pictures. They are most suitable for small object photography resulting in pictures you may need for your website, for internet auctions, for online shops or for documentation of valuables or collectables.

Studio-out-of-the-Box 2

Compact foldable studio for digital photography. Comprises table, background support, background material white, black and blue, smartphone mount and trapeze stand for cameras up to 500 g (1.1 lbs.). On the trapeze stand the camera can be positioned in many different positions and at different heights and distances from the object. The camera platform is pivotable and relocatable and can be locked in a vertical shooting position. Table can be extended up to 30 cm (11.8 in.), background can be positioned at different heights. Background rolls included, approx. 40 cm (15.7 in.) wide and 130 cm (4.25 ft.) long. To support wider backgrounds a clip-on rail is included. Dimensions (folded): 59 x 6 x 33 cm (23.2 x 2.4 x 13 in.). Supplied with carrying box. A suitable lighting set (2 x 8 W, 4000 K) is available as an accessory (5914).

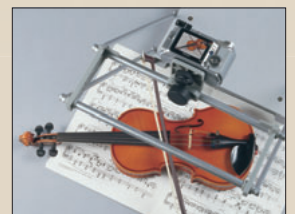
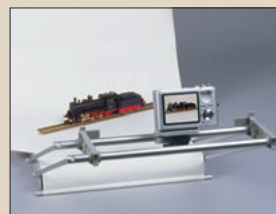
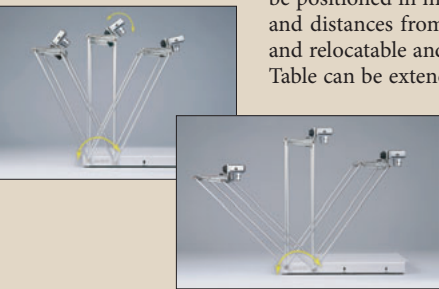

Table-Top-Studio digital

Complete desktop studio, consisting of Small Product Table 5931 and lighting unit. Product table with white translucent concave shaped acrylic background. Required desk space approx. 50 x 50 cm (20 x 20 in.). Lighting unit consists of two small soft lights for even and smooth illumination and holding rods with multiple orientation possibilities, screw-on clamps for attachment.

Table-Top-Studio digital SN-HF (5993) with RB 218N HF daylight lighting system (5464) with two compact fluorescents, 18 W each, 5400 K, CRI = 90-100. Table-Top-Studio digital SN-HF plus (5994) with additional camera clamp holder comprising a swan-neck arm, a ball head and a desk clamp.

Also available with RB 5020 DS LED daylight lighting system (5465) with 192 white high-CRI LEDs on each side: Table-Top-Studio digital LED (5995) and Table-Top-Studio digital LED plus (5996). Lights can be dimmed individually or synchronized, 5600 K, CRI = 85-90, angle of radiation: 60°.



5994

Universal Clamp

Attaches on tubes and boards. Span width max. 37 mm (1.5 in.). Two threaded holes 1/4" and 3/8". Includes spigot with 1/4" and 3/8" threaded pins.



5023

Mini Magic Arm

To mount and individually align cameras, lights and accessories. 1/4" mounting thread. Central locking knob. Comes with multiple mounting adapters. Maximum load in horizontal position: 1 kg (2.2 lbs.).

5055: Magic Arm mini 1, total length approx. 18 cm (7.1 in.)

5056: Magic Arm mini 2, total length approx. 29 cm (11.4 in.)



Photo Matt Spray

For quick and even dulling of shiny surfaces. Transparent, adheres well, can be removed. 400 ml.



6303



„easy-fit“ Shooting Table

5845: Compact shooting table, comprised of a foldable tubular steel frame and a white translucent plastic sheet with preformed front edge. Easy set-up and take-down without need of tools, space-saving storage. Base frame with nonskid feet and holding provisions for accessories on both sides.

Level work space on table: approx. 59 x 37 cm (23.2 x 14.6 in.). Height of backdrop: approx. 35 cm (13.8 in.). 19 cm (7.5 in.) free space underneath the table for a transmitted light source (light box). Total dimensions: (WxHxD): 70 x 54 x 68 cm (27.6 x 21.3 x 26.8 in.). Weight: approx. 3.4 kg (7½ lbs.).

„easy-fit“ Shooting Kit

5846: Consists of „easy-fit“ Shooting Table (5845) and Desktop Lighting Kit 2 (5862).

Desktop Lighting

5861: Desktop Lighting Kit 1: reflector light, consisting of lamp holder 5860, reflector (27 cm / 10.6 in. diameter) with removable diffusing cover and light stand 5859. Incl. energy saving lamp 3110.



5862: Desktop Lighting Kit 2, comprises two sets 5861.

5860: Lamp Holder with E27 ceramic socket, for photofloods up to 250 watts. With ON/OFF switch and swivel joint with umbrella mount. Mounts on suitable tripods/stands with 16 mm standard spigot. Mains lead approx. 3.80 m (12.5 ft). 1 piece. Without lamp and reflector.

5858: Desktop Light Stand, height 22-38 cm (8.7-15 in.)

5859: Desktop Light Stand, height 35-70 cm (13.8-27.6 in.)

3110: Energy Saving Lamp for photography, 23 W, 6500 K, 1600 lm, E27



NEW LED Desktop Light

5850: Compact soft-light with 96 high-CRI LEDs for color neutral illumination and diffuser screen for even softer light. Comes with adjustable foot and flexible bracket with three detent joints. The bracket can also be attached to the „easy-fit“ shooting table (5845) using the 1211 accessory shoe. Mains cord approx. 190 cm (74.8 in.) long, with cable switch. Foot and bracket can be folded to a compact size.

Color temperature: approx. 5600 K (daylight)

Color rendition index: CRI = 95

Illuminance (1 m/3.3 ft.): 480 lux

Operating voltage: 100-240 V

Dimensions (lighting unit) (WxHxD): approx. 14 x 20 x 2 to 3.5 cm (5.5 x 7.9 x 0.8 to 1.4 in.)

Maximum height with foot and bracket: 48 cm (18.9 in.)

NEW Photoflood

3106: LED Lamp, 15 Watt, 5600 Kelvin, CRI = 95, 1160 lm, 95-260 V, E27



„Cube-Studio“ Light Tent

This cube-shaped light tent allows for even and soft illumination. Detachable front cover with slot for camera lens. Easy to set up, folds up automatically. Highly flexible frame, can be folded down to compact size. Includes reversible textile backdrops white/grey and black/blue and carrying pouch with wrist strap.

5893: 50 x 50 x 50 cm (19.5 x 19.5 x 19.5 in.)

5894: 90 x 90 x 90 cm (35.5 x 35.5 x 35.5 in.)

Desktop Shooting Kit

Comprehensive kit for object photography. Consists of a „Cube-Studio“ light tent for even and soft light distribution and two reflector lights on desktop stands (Desktop Lighting Kit 2, code no. 5862).

5863: with Cube-Studio 5893 (50 x 50 x 50 cm)

5864: with Cube-Studio 5894 (90 x 90 x 90 cm)

Accessory Shoe

For attaching a 5850 LED Desktop Light to the „easy-fit“ shooting table.

1211



Sockets

Can be mounted on the „easy fit“ shooting table. For vertical or horizontal fastening of accessories with 16 mm standard spigot. 1 pair.

5847



„Dome-Studio“ Light Tent

White translucent surfaces provide even and soft illumination. Umbrella-type construction makes set-up and fold-down easy. Equipped with „snow flaps“ for outdoor use to prevent it from blowing away in strong winds. Supplied with reversible textile background (blue/grey) and protective cover with carrying straps.

5891: Floor size: 62 x 62 cm (24.5 x 24.5 in.), height: 51 cm (20 in.)

5892: Floor size: 75 x 75 cm (29.5 x 29.5 in.), height: 65 cm (25.5 in.)



5891

For Everything That Won't Fit Your Scanner!

Just in case something would not fit on your scanner – too big, too bulky, too wide etc. – here is where it belongs. Combine these stands with your camera and enjoy a perfect image capturing tool for all „awkward“ items that need to be photographed from above: the vintage LP cover, grandfather's precious pocket watch or just a section out of a large-sized road map. Suitable lights – now also available with LEDs – for even illumination, can easily be added.



Made in Germany

5360

„reprokid“ Copy Stand

Super-compact copy stand for small, lightweight cameras. Non-reflective, matt-black base board. Column with cm/inch scale. Height-adjustable camera arm. 1/4" mounting thread. Base board (WxHxD): 32 x 1.9 x 38 cm (12.6 x 0.7 x 15 in.). Column height: 59 cm (23.2 in.). Max. load: 1 kg (2.2 lbs.). Includes lighting unit with two E27 screw-in mounts for lamps up to 250 watt (supplied without lamps). Code no. 5360

Suitable lighting units for RS 2 XA copy stand:

RB 5020 DS LED Lighting Unit



5465

With two small light banks, each with 192 white high-CRI LEDs, 5600 K, angle of radiation: 60°. Lights can be dimmed individually or synchronized. Lights are tiltable and adjustable in height. Angle of vertical arms adjustable by lock joint. Mounted with strong die-cast clamp bases. Code no. 5465

RB 218N HF Lighting Unit

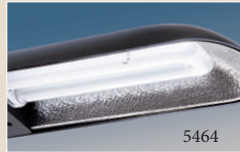

5464

With two small light banks with interior reflector and 18 W, 5400 K daylight fluorescent lamp. High frequency operating system. Lights are tiltable and adjustable in height. Angle of vertical arms adjustable by lock joint. Mounted with strong die-cast clamp bases. Code no. 5464



5411 with 5465

Made in Germany

RS 2 XA Camera Stand

Non-reflective matt grey base board with printed fine grid and cm/inch scale. Matt-black anodised aluminium-section tube column with cm/inch scale. Hand-cranked height adjustment. Horizontally adjustable camera arm. 1/4" mounting thread. Base board (WxHxD): approx. 40 x 2.5 x 50 cm (15.7 x 1 x 19.7 in.). Column height: approx. 76 cm (30 in.). Maximum load: 1.5 kg (3.3 lbs.). Code no. 5411



Slim Figure

NEW slimlite plano

Super flat light boxes, only 8 mm thin, with built-in rechargeable battery. Illumination by daylight-type LEDs (approx. 5000 Kelvin). Touch switch for ON/OFF and brightness control. cm and inch scales. Optional mains or battery operation. Mains/charging adapter included.

2453: Illuminated area: 22 x 16 cm (8.7 x 6.3 in.)
Light source: 23 LEDs, 5000 Kelvin
Lithium ion battery: 1050 mA
Dimensions (WxHxD): 29 x 0.8 x 20 cm (11.4 x 0.3 x 7.9 in.)
Weight: 570 g (20.1 oz.)

2454: Illuminated area: 32 x 22.8 cm (12.6 x 9 in.)
Light source: 33 LEDs, 5000 Kelvin
Lithium ion battery: 1050 mA
Dimensions (WxHxD): 39 x 0.8 x 27 cm (15.4 x 0.3 x 10.6 in.)
Weight: 1010 g (35.6 oz.)

8 mm

KAISER
FOTOTECHNIK

Equipment for the Ambitious Photographer

Taking pictures of somewhat larger objects is often much easier when you use a suitable shooting table. The advantage compared with any provisional workaround is quite simply visible in your pictures: a smooth white background, brilliant illumination and more flexibility with respect to the appropriate perspective.

„TopTable XL Vario“ Shooting Table

NEW Translucent plastic sheet with matte non-reflective surface and preformed front edge. Aluminum frame with four lockable castors. Adjustable backdrop angle.

Level work space on table (WxD): approx. 94 x 90 cm (37 x 35.4 in.), working height approx. 73 cm (28.7 in.)

Height of backdrop: up to 78 cm (30.7 in.)

Total height with backdrop in vertical position (WxHxD): approx. 116 x 151 x 138 cm (45.7 x 59.4 x 54.3 in.)

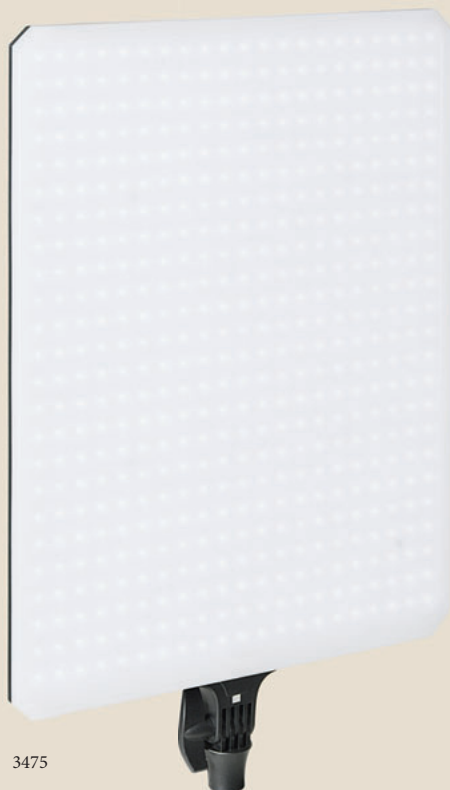

NEW PL5600 Studio Light

Soft light with 504 high CRI LEDs for photo and video shooting. Sturdy, slim plastic housing. Almost no heat load and low power consumption. Continuously adjustable illumination, can be dimmed between 10% and 100%. Slip-on fabric diffuser for still softer illumination. Swivel joint with receptacle for 16 mm standard spigot.

Specifications

Panel size (WxH): 40 x 55 cm (15.7 x 21.7 in.)
 Illuminance (1 m/3.3 ft.): 2100 lux
 Color temperature: approx. 5600 K
 Color rendition index: CRI = 95
 Operating voltage: 100-240 V
 Dimensions (w/swivel joint) (WxHxD): approx. 40 x 65 x 3 to 5 cm (15.7 x 25.6 x 1.2 to 2 in.)

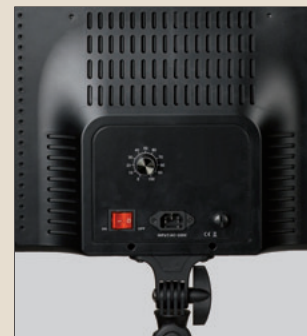

Light stand 3195

Luminaries

The lights of the „PL Vario“ and the „studiolight“ line are absolutely suitable for the small home studio. They are compact, sturdy, easy to use, and the lighting situation is the same for set-up and shooting.

„PL Vario“ LED Soft Lights

These soft lights are designed for studio use mounted on light stands, providing soft and even illumination for photo and video. The light is free from infrared and UV content and completely flicker-free and with no residual ripple due to DC operation. There is almost no heat load. Light intensity and color temperature can be adjusted continuously via control dials on the rear side of the lights.

If several lights are used together, they can be controlled by one dial provided that they are connected via a controller cable. Generally the lights are powered by the mains adapter supplied with the units, there is also the option for using power packs. All lights can be tilted, the mounting bracket can be detached. Mounting on stands via 16 mm or 28 mm (0.6 in. or 1.1 in.) standard spigot.

3473

3472

3470



3472



3473

Code no.	3470	3472	3473
Type	PL240 Vario	PL360 Vario	PL840 Vario
LEDs	240	360	840
Color temperature	3200-5600 K	3200-5600 K	3200-5600 K
Color reproduction index	CRI = 85-90	CRI = 85-90	CRI = 85-90
Angle of radiation	50°	50°	50°
Max. illuminance (lux)	1 m: 2000 2 m: 500 3 m: 220	1 m: 2570 2 m: 640 3 m: 290	1 m: 7270 2 m: 1820 3 m: 810
Additional features	Front screen	Front screen	4 barn doors
Operating voltage	6-18 V (DC)	10-18 V (DC)	10-18 V (DC)
Dimensions (cm/in.)	35 x 23 x 5.5 13.8 x 9.1 x 2.2	35 x 37.5 x 6.5 13.8 x 14.8 x 2.6	35 x 37.5 x 6.5 13.8 x 14.8 x 2.6
Weight (g/oz.)	1000 / 35.2	1680 / 59.2	1730 / 60.9
Scope of supply	Diffusor screen, connecting adapter for additional light, controller cable		

Light Stands

3195-96: Sturdy matt black light stands with 1/4" / 3/8" reversible thread pin, that can be attached either vertically or horizontally. The center column is air cushioned and thus provides secure use.

3195: „Small“ Light Stand.
Four section center column.
Setting height: approx. 75-230 cm (29.5-90.6 in.)
Length closed: approx. 70 cm (27.6 in.)
Max. load: 3 kg (6.6 lbs.)
Weight: approx. 1.65 kg (3.6 lbs.)

3196: „Large“ Light Stand.
Three section center column.
Setting height: approx. 110-290 cm (43.3-114.2 in.)
Length closed: approx. 105 cm (41.3 in.)
Max. load: 10 kg (22 lbs.)
Weight: approx. 2.2 kg (4.9 lbs.)



3195-96

3198: Mobile and extremely stable light stand. Folding legs with lockable pivoting rollers. Hole for standard 28 mm (1.1 in.) spigot, concealed standard 16 mm (0.6 in.) spigot.



Setting height: 131 to 217 cm (51.6 to 85.4 in.)
Max. load: 25 kg (55 lbs.)
Weight: 7.6 kg (16.7 lbs.)

3198

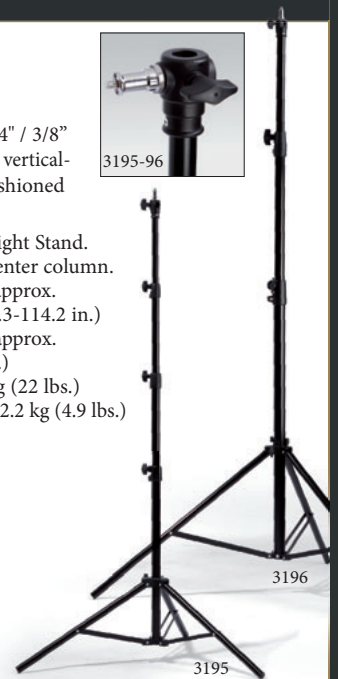

3196

3195

NEW

3190: „VarioBase 300“ Light Stand.
With three levelling legs, all adjustable in setting angle and length. Four section extendible center column. With 16 mm standard spigot and 1/4" connecting thread.

Setting height: approx. 63-298 cm (24.8-117.3 in.)
Pack size: approx. 63 cm (24.8 in.)
Max. load: 6 kg (13.2 lbs.)
Weight: approx. 1.8 kg (4 lbs.)

3190



„studiolight 1010“ Halogen Studio Lighting Unit

With 1000 Watt halogen lamp and protective lamp cover made of safety glass. Brightness can be adjusted via step-up/step-down buttons, two-digit display. Light can be switched from set brightness to full brightness and back. Low-noise blower cooling for unlimited operation in every position. Bayonet attachment with quick locking device for accessories (reflectors, soft boxes), swivel joint with locking lever, umbrella mount. Mounts on suitable tripods/stands with 16 mm standard spigot. Includes halogen lamp, exchangeable reflector (180 mm / 7 in. diameter) and protective lamp cover. Code no. 3164



„studiolight 1010 Kit“ Lighting Kit

Comprised of 2 „studiolight 1010“ halogen lighting units (3164), 2 heat resistant soft boxes 60 x 90 cm (23.6 x 35.4 in.) and 2 air-cushioned light stands (setting height 75-230 cm / 29.5-90.6 in.) in a sturdy carrying case. Outside dimensions: 73 x 28 x 44 cm (28.7 x 11 x 17.3 in.). Code no. 3165



3165

Additional accessories for studiolight 1010 (with Bowens compatible bayonet mount):



„Beauty Dish“ Reflector

Wide beam. With secondary reflector.



Reflector

Narrow beam. Silver coating inside. Matte black coating outside.



Background Reflector

Can be rotated and locked in any position. Silver coating inside.



Softbox

Heat-resistant, with ventilation flaps. Can be rotated. 60 x 90 cm (23.5 x 35.5 in.)



„studiolight E70“ Lighting Kit

Comprised of two soft boxes 50 x 50 cm (20 x 20 in.) with incorporated E27 lamp socket and swivel joint, two daylight photofloods 3115, two light stands and carrying bag. Soft boxes with umbrella mechanism for fast and simple setup. Detachable front diffuser. Tiltable lamp holder with 2.8 m (9.2 ft.) mains lead and cable switch. Can be equipped with compact fluorescents up to 200 watt and up to 31 cm (12.2 in.) overall length. Not suitable for incandescents. Light stands have setting height of 70 - 190 cm (27.6 - 74.8 in.), 16 mm standard spigot and 1/4" tripod thread.

Padded carrying bag with handle and detachable shoulder strap.



3167

Photoflood

For 3167. Energy saving lamp 65 W, 5500 K, E27, 3900 lm, 230 V.



3115



More Information

The comprehensive Kaiser range of products can be found in the Kaiser general catalogue, available from your dealer or through the Kaiser distributor in your country. You can also download the catalogue chapter by chapter from our website at www.kaiser-fototechnik.de.



For the image capturing of two-dimensional originals and objects with minor height Kaiser Fototechnik offers a comprehensive range of high-quality products.

Detailed information can be found in the „Copy Stands & Lighting Equipment“ leaflet.



USA
MAC Group
75 Virginia Road,
North White Plains, NY 10603
Tel +1 914 3473300
Fax +1 914 3473309
info@macgroupus.com
www.macgroupus.com

United Kingdom
Fotospeed Distribution
Jay House Ltd.
6B, Park Lane Industrial Estate
Park Lane, Corsham
Wilts, SN13 9LG
Tel +44 1249 714 555
Fax +44 1249 714 999
info@fotospeed.com
www.fotospeed.com

Canada
Nadel Enterprises Inc.
3320 Caroga Drive
Mississauga, Ontario
L4V 1V4
Tel +1 416 7452622
Fax +1 416 7422616
info@nadel.ca
www.nadel.ca

New Zealand
Photo Warehouse Ltd.
175 GT North Rd.
Ponsonby-Auckland
Tel +64 9 3032148
Fax +64 9 3099721
saless@photowarehouse.co.nz
www.photowarehouse.co.nz

Lighting equipment and lamps as described in this brochure are marketed for the primary purpose of illumination for image capture and not for household lighting.

WEEE-Rg.-Nr. DE 34742207

Kaiser Fototechnik GmbH & Co. KG
Im Krötensteich 2 · 74722 Buchen · Germany
Tel.: +49 6281 4070
Fax: +49 6281 40755
www.kaiser-fototechnik.de
info@kaiser-fototechnik.de

